

Surge Arresters

Electrical Apparatus
235-68

Metal Oxide Varistor (MOV) Parking Stand Surge Arrester

GENERAL

The Cooper Power Systems Parking Stand Arrester combines metal (zinc) oxide varistor technology with a premolded rubber insulated standoff bushing. The arrester provides overvoltage system protection in an insulated, fully shielded, submersible, deadfront device. The standoff bushing interface conforms to IEEE Std 386™ standard – Separable Insulated Connector Systems. The arrester housing provides necessary deadfront safety.

Parking stand arresters are used on underground systems in pad-mounted transformers and entry cabinets, vaults, switching enclosures and other installations to provide shielded deadfront arrester protection.

CONSTRUCTION

The rubber body is constructed of high quality precision molded peroxide cured EPDM insulation and semiconductive materials.

This ensures that the column cannot be damaged during installation and that a reliable current path to the MOV blocks is maintained. The disk column is composed of MOV disks bonded together with high-conductivity, silver-loaded epoxy to yield the most reliable electrical connection and eliminate air voids. The #4 AWG flexible copper ground lead, which reliably carries current to ground during voltage surges, is attached to the housing by a brass magneformed end cap. The brass end cap provides a tight, weatherproof seal.

OPERATION

Parking stand arresters are designed for use with 200 A loadbreak interfaces that conform to IEEE Std 386™ standard to limit overvoltages to acceptable levels, protect equipment and extend cable life. Parking stand arresters also provide an economical means of overvoltage protection for energized but parked open point cable runs.

Installation time and space are reduced as the parking stand arrester replaces a MOV elbow arrester and portable feedthru in this application. See Catalog Section 235-65, for information on the MOV elbow arrester for protection of



Figure 1.
25 kV and 15 kV Parking Stand MOV Gapped Arresters.

the other side of loop, radial applications and mid-line protection.

The parking stand arrester is designed to be installed in the parking stand bracket found on the frontplate of a transformer or other apparatus. The molded EPDM rubber body is held in a stainless steel bracket assembly. A stainless steel eyebolt is used to secure the parking stand arrester in the parking stand bracket.

STANDARDS

The parking stand arrester complies with the latest revision of IEEE Std C62.11™ standard "IEEE Standard for Metal Oxide Surge Arresters for AC Power Circuits" and IEEE Std 386™ standard "Separable Insulated Connectors for Power Distribution Systems Above 600 Volts."

INSTALLATION

No special tools are required. The

arrester is placed in a parking stand bracket with a hotstick. Refer to Installation Instruction Sheet S235-58-1 for more details.

PRODUCTION TESTS

Tests conducted in accordance with IEEE Std 386™ standard:

- Corona Extinction Voltage Level
- AC 60 Hz 1 Minute Withstand

Tests conducted in accordance with Cooper Power Systems requirements:

- Physical Inspection
- Periodic Dissection
- MOV Blocks:
 - Voltage at 1 mA
 - Batch Life Test
- Arrester Assembly:
 - Voltage at 1 mA
- Periodic X-ray Analysis

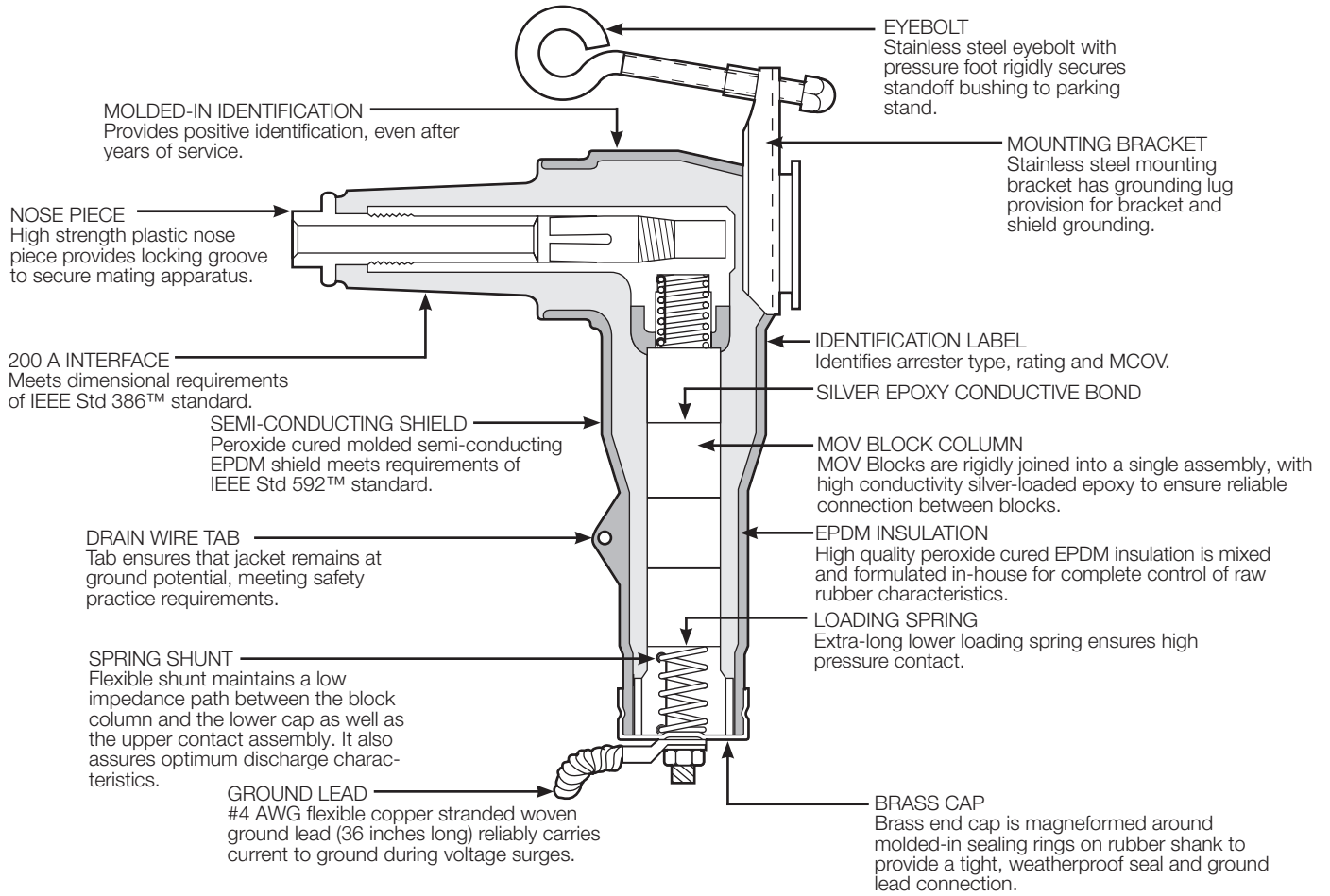

Figure 2. Cutaway illustration shows 25 kV Class Metal Oxide Varistor Parking Stand Surge Arrester.

PROTECTIVE CHARACTERISTICS

The protective characteristics of the M.O.V.E. Surge Arrester are shown in Table 1.

TABLE 1
Electrical Ratings and Characteristics

Duty Cycle Voltage Rating (kV)	MCOV (kV)	Equivalent Front-of-Wave (kV crest)*	Maximum Discharge Voltage (kV crest) 8/20 μ s Current Wave				
			1.5 kA	3 kA	5 kA	10 kA	20 kA
3	2.55	13.7	10.7	12.0	12.8	13.4	15.7
6	5.1	27.4	21.9	24.5	26.2	28.6	34.9
9	7.65	37.4	27.4	29.9	31.4	34.7	38.4
10	8.4	39.7	28.4	30.6	32.9	36.7	40.4
12	10.2	56.1	41.1	44.8	47.1	52.0	57.6
15	12.7	63.0	45.0	49.2	52.5	57.8	66.0
18	15.3	74.8	54.7	59.7	62.7	69.3	76.8
21	17.0	81.7	58.7	64.2	68.2	75.2	85.2

* Equivalent front-of-wave voltage is the expected discharge voltage of the arrester when tested with a 5 kA current surge cresting in 0.5 μ s.

TEMPORARY OVERVOLTAGE (TOV) CAPABILITY

The Temporary Overvoltage (TOV) capability of the parking stand arrester is shown in Figure 3.

PERFORMANCE TEST CHARACTERISTICS

The parking stand arrester consistently withstands the following design tests as described by IEEE Std C62.11™ standard:

- Duty Cycle:
22 current surges of 5 kA crest
8/20 μs waveshape.
- High-Current, Short-Duration Discharge:
2 current surges of 40 kA crest
4/10 μs waveshape.
- Low-Current, Long-Duration Discharge:
20 current surges of 75 A crest
2000 μs rectangular wave duration.

Following each of these tests, the arresters remain thermally stable as verified by:

- Continually decreasing power values during a thirty minute power monitoring period.
- No evidence of physical or electrical deterioration.

STANDARDS

The parking stand arrester complies with the latest revision of IEEE Std C62.11™ standard "IEEE Standard for Metal Oxide Surge Arresters for AC Power Circuits" and IEEE Std 386™ standard "Separable Insulated Connectors for Power Distribution Systems Above 600 Volts."

TABLE 2
Commonly Applied Voltage Ratings of MOV Parking Stand Arrester

System Voltage (V rms)		Commonly Applied Arrester Duty-cycle (MCOV) Voltage Rating (kV rms) on Distribution Systems		
Nominal Voltage	Maximum Voltage range B	4-Wire Multigrounded Neutral Wye	3-Wire Low Impedance Grounded	Delta and 3-Wire High Impedance Grounded
2400	2540	–	–	3 (2.55)
4160 Y/2400	4400 Y/2540	3 (2.55)	6 (5.1)	6 (5.1)
4260	4400	–	–	6 (5.1)
4800	5080	–	–	6 (5.1)
6900	7260	–	–	9 (7.65)
8320 Y/4800	8800 Y/5080	6 (5.1)	9 (7.65)	–
12000 Y/6930	12700 Y/7330	9 (7.65)	12 (10.2)	–
12470 Y/7200	13200 Y/7620	9 (7.65) or 10 (8.4)	15 (12.7)	–
13200 Y/7620	13970 Y/8070	10 (8.4)	15 (12.7)	–
13800 Y/7970	14520 Y/8388	10 (8.4) and 12 (10.2)	15 (12.7)	–
13800	14520	–	–	18 (15.3)
20780 Y/12000	22000 Y/12700	15 (12.7)	21 (17.0)	–
22860 Y/12000	22000 Y/12700	15 (12.7)	21 (17.0)	–
24940 Y/14400	26400 Y/15240	18 (15.3)	27 (22.0)	–
27600 Y/15935	29255 Y/16890	21 (17.0)	–	–
34500 Y/19920	36510 Y/21080	27 (22.0)	–	–

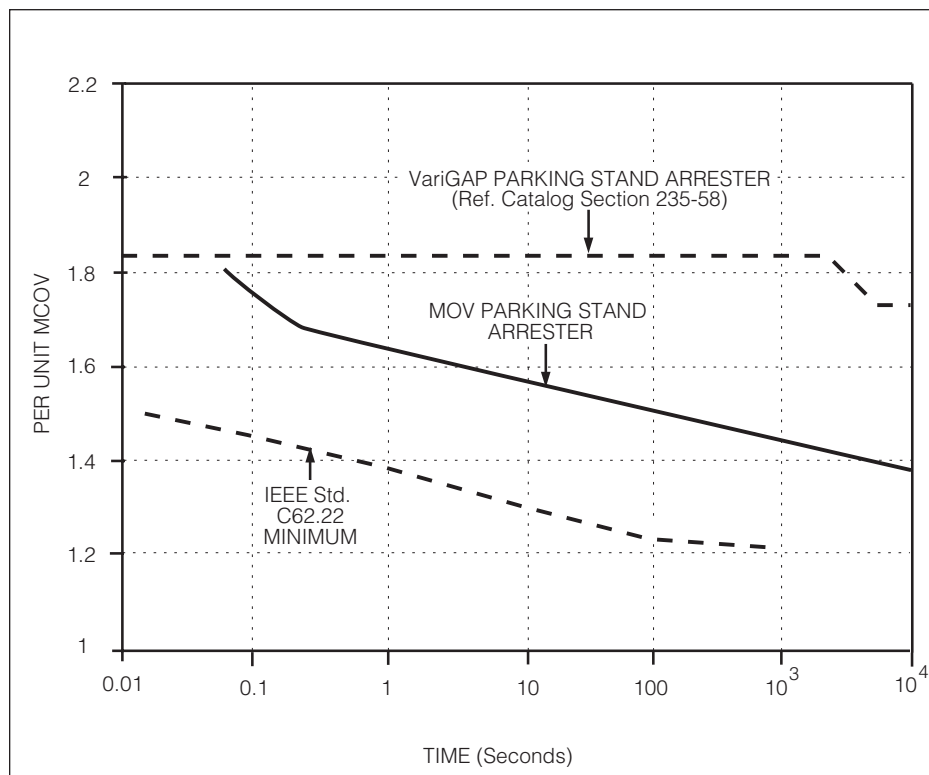

Figure 3.
Temporary overvoltage curve. No prior duty at 85° C ambient.

ORDERING INFORMATION

To order a parking stand surge arrester kit, determine the arrester Maximum Continuous Operating Voltage (MCOV) rating for the intended application using Table 4 and specify the appropriate catalog number from Table 3. Contact the Cooper Power Systems sales engineer in your location for applications not listed.

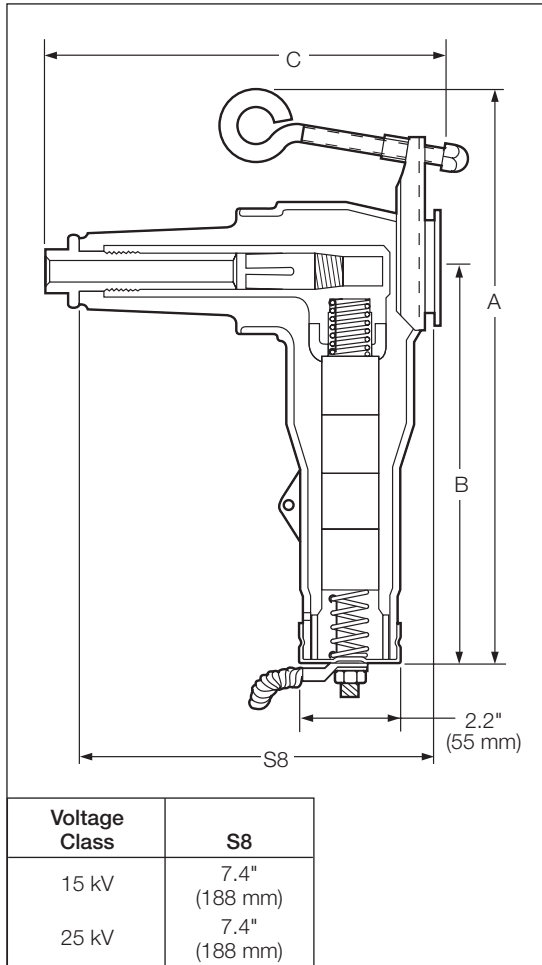

Figure 4. Dimensional information of Parking Stand Surge Arrester (refer to Table 3).

Note: Dimensions given are for reference only.

TABLE 3
Parking Stand Surge Arrester Selection Chart

IEEE Std 386™ standard Interface	Duty Cycle (kV)	MCOV Rating (kV)	Dimensions in./(mm)			Catalog Number
			A	B	C	
15 kV Class	3	2.55	11.9	8.0	7.7	3237686C03M
			(302)	(203)	(196)	
	6	5.1	11.9	8.0	7.7	3237686C06M
			(302)	(203)	(196)	
	9	7.65	11.9	8.0	7.7	3237686C09M
			(302)	(203)	(196)	
	10	8.4	11.9	8.0	7.7	3237686C10M
			(302)	(203)	(196)	
	12	10.2	11.9	8.0	7.7	3237686C12M
			(302)	(203)	(196)	
25 kV Class	9	7.65	11.9	8.0	8.2	3237758C09M
			(302)	(203)	(208)	
	10	8.4	11.9	8.0	8.2	3237758C10M
			(302)	(203)	(208)	
	12	10.2	11.9	8.0	8.2	3237758C12M
			(302)	(203)	(208)	
	15	12.7	11.9	8.0	8.2	3237758C15M
			(302)	(203)	(208)	
	18	15.3	11.9	8.0	8.2	3237758C18M
			(302)	(203)	(208)	
	21	17.0	11.9	8.0	8.2	3237758C21M
			(302)	(203)	(208)	