

GENERAL

Cooper Power Systems V-GRAPH™ software is an intuitive Microsoft® Windows® one-line diagram drawing program for modeling and studying electrical power systems. It is the graphical interface to the Power Verdict™ Series on which you can display the results of any or all Power Verdict programs. Its flexibility gives you the ability to define your own graphical symbols and display attributes at any time.

The program's features make the task of drawing one-line diagrams easier. A typical use would be to edit devices of a one-line diagram to prepare data for the next run of a Power Verdict program, and then display the results. Entire diagrams or selected portions can be pasted into Windows word processing and spreadsheet programs. This is ideal for producing reports.

OPERATION

You simply draw the one-line and click on device symbols to enter data. There is no need to directly access or navigate layers of database files. Invoked by a single keystroke, the program's help system provides you with detailed explanations of one-line drawing techniques and device parameters. The help system is context sensitive, which means messages are queued to correspond with the active window. This on-line help also corresponds directly to the User's Manual.

Bitmapped symbols representing power system devices may be customized to your standards for symbol shapes. The program can support device installations to either side of buses, so a separate symbol is not required for each orientation. It allows you to draw uniform or variable length buses, and to resize drawn buses. You can set preferences for automatic device naming, font types and coloring of buses and devices. Once installed, devices and labels may be freely repositioned along the bus of attachment. Lines can be drawn with multiple intermediate segments, which can be individually repositioned.

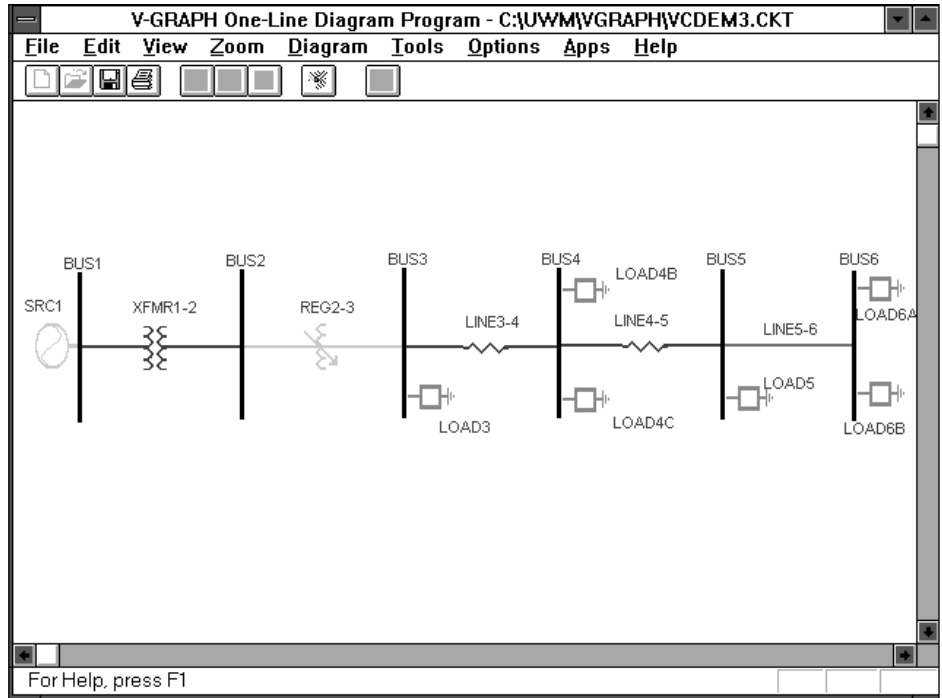

Figure 1.
V-GRAPH drawing screen.

The screenshot shows the "Generic Load Model" dialog box. The "Device Name" field contains "LOAD3". Under "Load Connection", "Bus Connection" is selected. The "Name of Associated Daily Curve" is "DEFAULT" and the "Name of Associated Seasonal Curve" is "DEFAULT". The "Load Model" is "2.) Constant P and Q, regardless of voltage.". The "Type of Load" section has "(P,Q)" selected. The parameters are: P: 450, Q: 225, S: 0, PF: 0, VA conn.: 0, Wh: 0, PF: 0. A note at the bottom states: "NOTE: Power Factor convention: + for Lagging, - for Leading". Buttons for "OK" and "Cancel" are at the bottom right.

Figure 2.
Load dialog box.

Features and Detailed Description

EFFICIENCY FEATURES

The V-GRAPH program contains many built-in features to maximize user efficiency. For example, you may create a library of common devices (e.g., line codes) to be used by several circuits.

You can define a subset of buses or branches for which to display Power Verdict analysis results. You may also define an additional subset of the type of results to display. For example, of the possible fault current types you may wish to view only three-phase fault currents.

Default name prefixes may also be customized to correspond to company standards. This may eliminate the need to modify names during device installation.

CUSTOMIZABLE OUTPUT

In addition to allowing clipboard copying of an entire one-line, the V-GRAPH program allows you to specify selected regions of the one-line to copy. This may be useful if a particular region of the power system is to be summarized in a report.

The optional header of a one-line diagram printout is user-definable. A timestamp of printing is also optional.

DATA VERIFICATION

All of the device dialog boxes contain a validation system. Entered data is checked against database minimum and maximum allowed values. The program also checks for pre-existing device names and warns of naming conflicts.

ADVANTAGES

- Centralized access to a common database greatly facilitates modeling and studying electrical power systems.
- The program takes full advantage of Windows memory management capabilities.
- A one-line diagram for use by a Power Verdict Series program can be quickly constructed.
- A library of devices can be maintained within the program, so you don't have to reenter the same data.
- One-line diagrams can be pasted into standard Windows spreadsheet or word processing applications.
- Extensive context-sensitive on-line help is available.
- Custom symbols can be created.

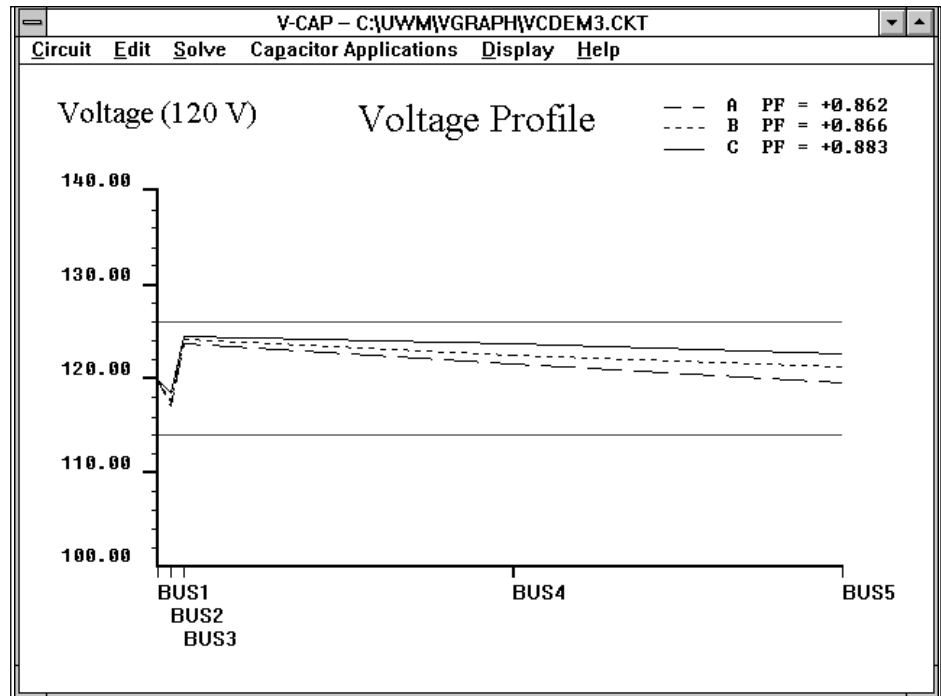

Figure 3.
V-CAP analysis using V-GRAPH circuit.

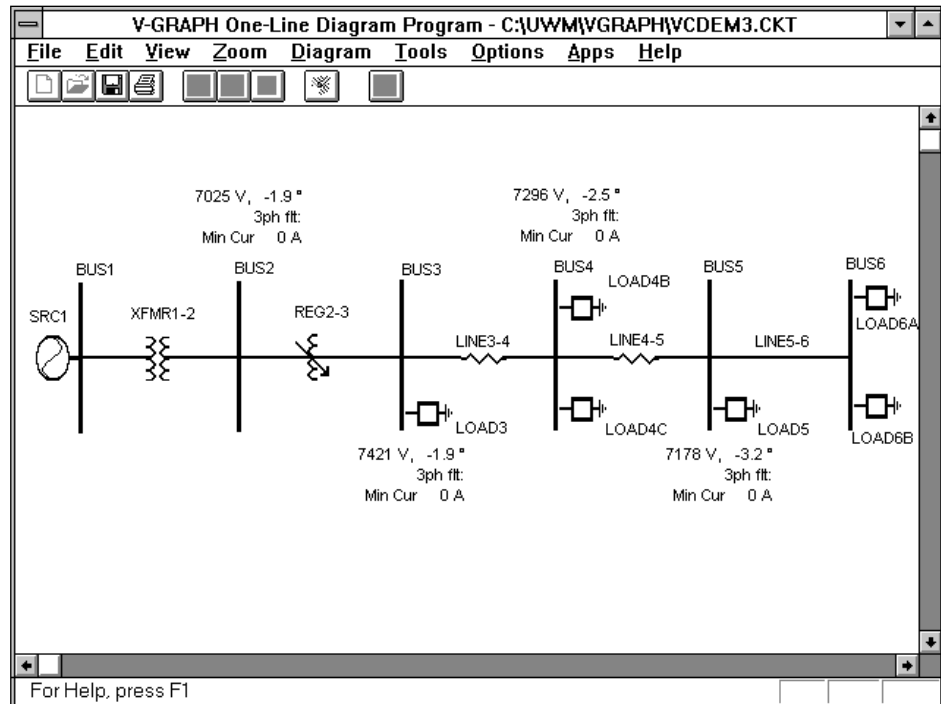

Figure 4.
V-CAP bus results in V-GRAPH.

APPLICATIONS

- In addition to serving as an interface to the database, the V-GRAPH program can also display the results from all Power Verdict programs.
- Very large power systems can be modeled.
- By switching the display mode from Editing to Analysis any results associated with bus or branch devices may be viewed. Results may be understood more quickly than by examining large tables of data.
- Results from Power Verdict programs can be displayed including losses, currents, power flows and voltages (magnitudes and angles).
- Results can also be displayed in tabular form, similar to those in spreadsheet programs.
- Study reports can be generated quickly.

ADDITIONAL FEATURES

- Print Preview allows you to view the appearance of the diagram before it is printed.
- Print Setup allows you to change printer connections within the program.
- Intuitive toolbars invoke various drawing modes.
- Auto Save periodically saves the active one-line diagram.
- An Undo function provides recovery from accidental deletions.
- The Scrolling and Zoom features allow you to select portions of the active one-line diagram to display in the view window.

OTHER ANALYSIS

PRODUCTS AND SERVICES

V-GRAPH software is part of a complete distribution analysis package offered by Cooper Power Systems. Related products include:

- Power Verdict Series of interactive software developed by Systems Engineering to analyze and troubleshoot utility and industrial systems.
- Engineering Workshops.
- Power System Studies.
- Transient, Harmonic, and Voltage Flicker Measurements.
- Technical Publications.

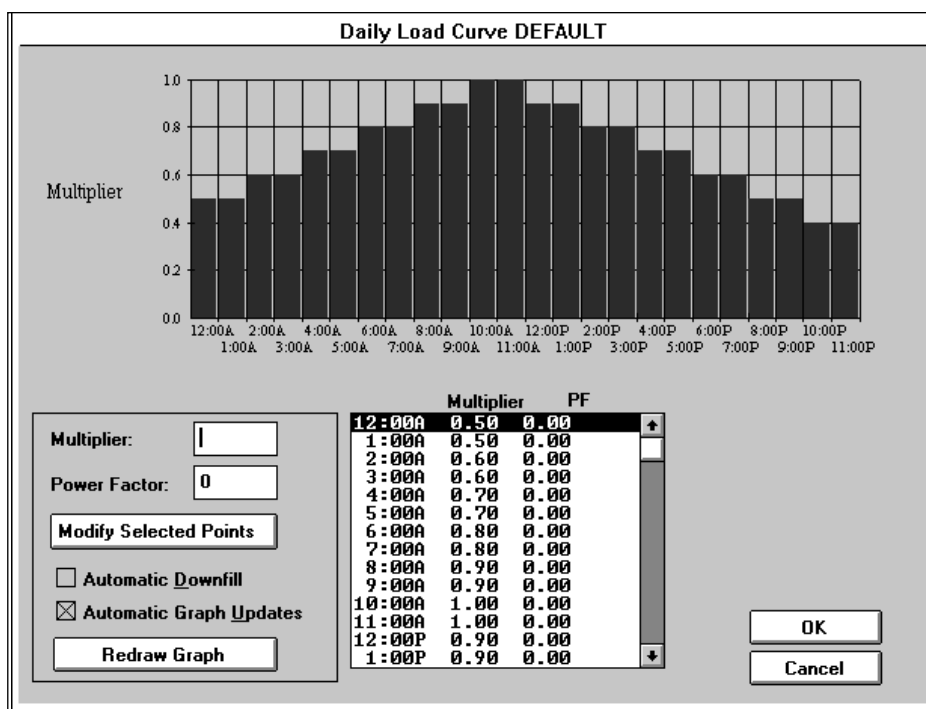

Figure 5.
Load curve editing.

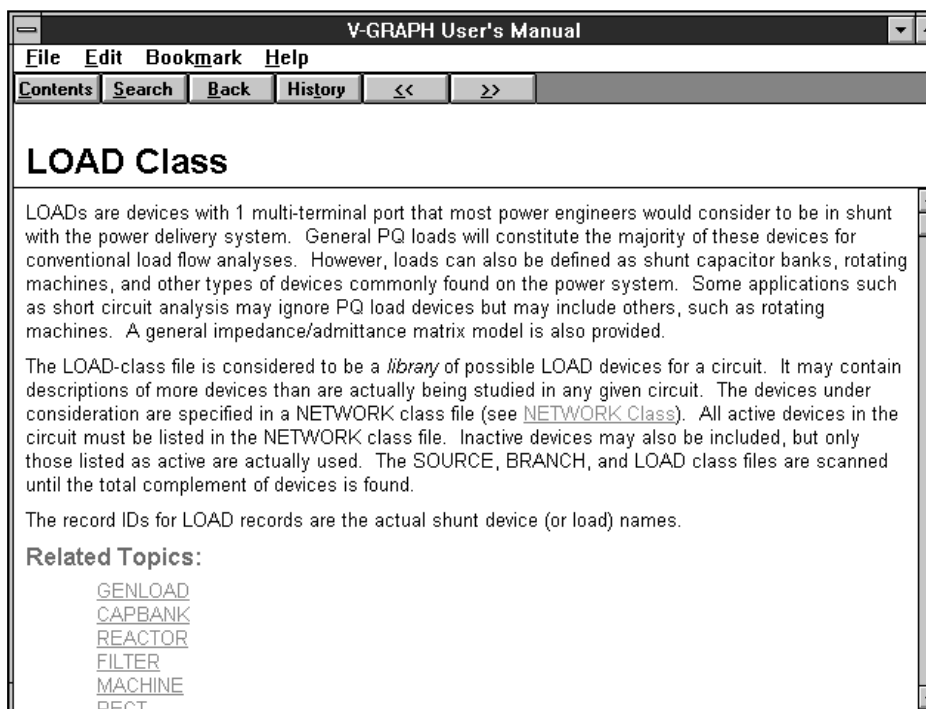

Figure 6.
Context sensitive help for load class.

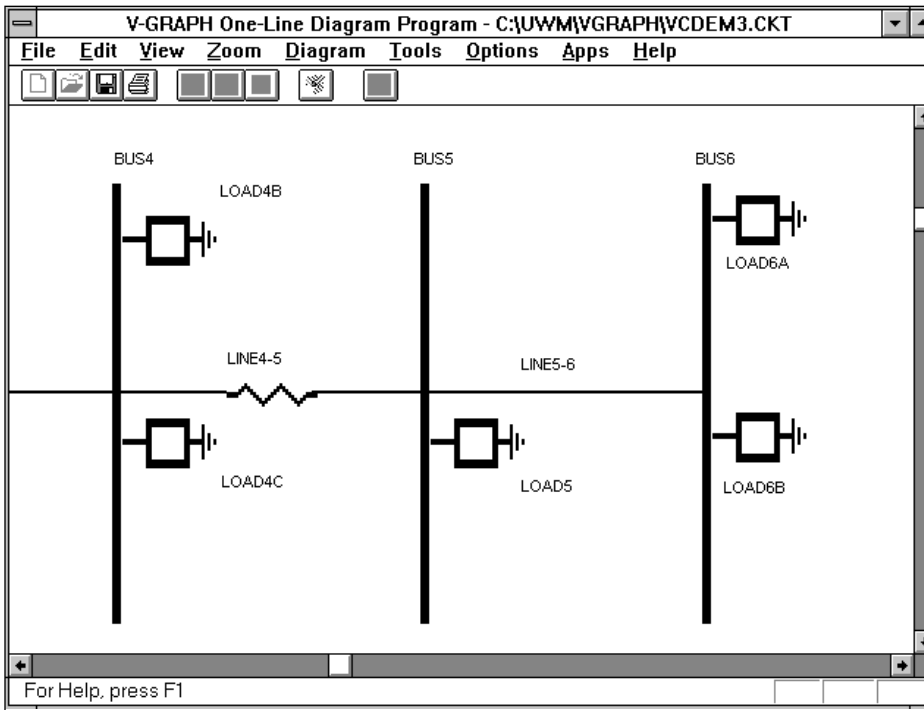

Figure 7.
V-GRAPH scaling.

Other software in the Power Verdict Series includes:

- V-CAP™, The Circuit Analysis Verdict™, regulator and capacitor application program.
- V-PRO®, The Protection Verdict™, graphics-oriented overcurrent protection coordination program.
- V-NET™, The Network Fault Verdict™, for complete fault analysis.
- V-FLOW™, The Power Flow Verdict™, for utility and industrial system network or radial power flows.
- V-HARM™, The Harmonics Verdict™, to calculate harmonic levels that replicate field tests and measurements.

For more information contact your Cooper Power Systems representatives or:

Systems Engineering Group
Thomas A. Edison Technical Center
11131 Adams Rd., P. O. Box 100
Franksville, WI 53126-0100
(414) 835-2921
(414) 835-1544 (Fax)

The screenshot shows the "2- and 3-Winding Transformer" dialog box. The "Device Name" is set to "XFMR1-2". The dialog is organized into columns for Primary, Secondary, and Tertiary windings. The Primary winding has a voltage of 34.5 kV, impedance of 0.7% and 7%, and a BIL of 125 kV. The Secondary winding has a voltage of 12.47 kV, impedance of 0.35% and 35%, and a BIL of 30 kV. The Tertiary winding has a voltage of 0 kV, impedance of 0.35% and 35%, and a BIL of 30 kV. The winding connection is set to Wye for Primary and Secondary, and Delta for Tertiary. The dialog also includes options for KV, kVA Type (Line-Neutral or Line-Line), exciting current at 100% and 110% voltage, no load loss, load loss, and kVA ratings for each winding. The "Number of Tap Ratings" is set to 1. The "Cooling Types Vector..." button is also visible.

Figure 8.
Transformer code dialog box.



Cooper Power Systems

GENERAL

Cooper Power Systems V-GRAPH™ software is an intuitive Microsoft® Windows® one-line diagram drawing program for modeling and studying electrical power systems. It is the graphical interface to the Power Verdict™ Series on which you can display the results of any or all Power Verdict programs. Its flexibility gives you the ability to define your own graphical symbols and display attributes at any time.

The program's features make the task of drawing one-line diagrams easier. A typical use would be to edit devices of a one-line diagram to prepare data for the next run of a Power Verdict program, and then display the results. Entire diagrams or selected portions can be pasted into Windows word processing and spreadsheet programs. This is ideal for producing reports.

OPERATION

You simply draw the one-line and click on device symbols to enter data. There is no need to directly access or navigate layers of database files. Invoked by a single keystroke, the program's help system provides you with detailed explanations of one-line drawing techniques and device parameters. The help system is context sensitive, which means messages are queued to correspond with the active window. This on-line help also corresponds directly to the User's Manual.

Bitmapped symbols representing power system devices may be customized to your standards for symbol shapes. The program can support device installations to either side of buses, so a separate symbol is not required for each orientation. It allows you to draw uniform or variable length buses, and to resize drawn buses. You can set preferences for automatic device naming, font types and coloring of buses and devices. Once installed, devices and labels may be freely repositioned along the bus of attachment. Lines can be drawn with multiple intermediate segments, which can be individually repositioned.

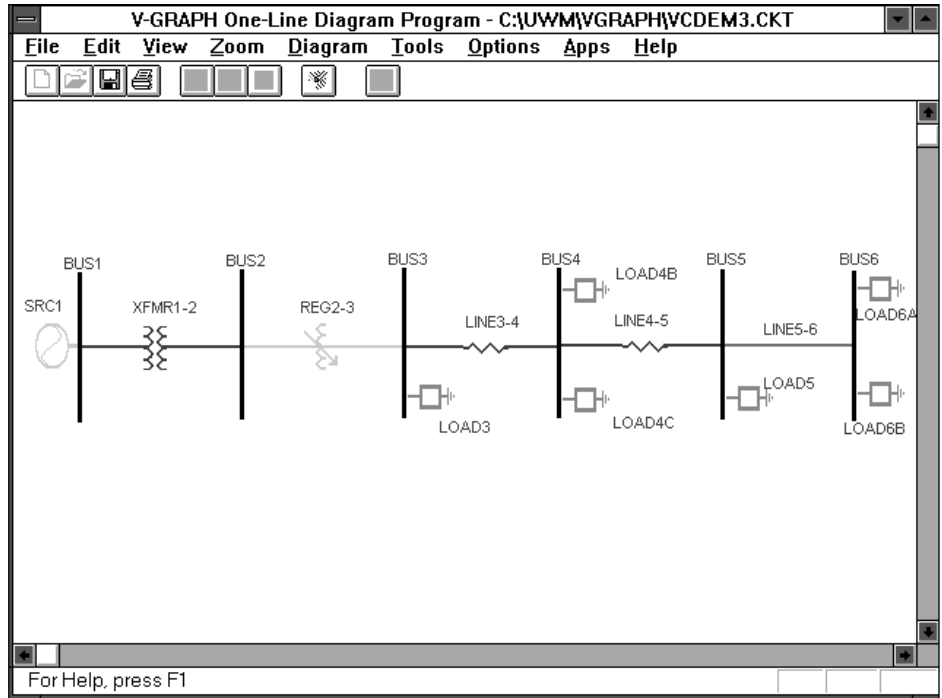

Figure 1.
V-GRAPH drawing screen.

The screenshot shows the "Generic Load Model" dialog box. The "Device Name" field contains "LOAD3". Under "Load Connection", "Bus Connection" is selected. The "Name of Associated Daily Curve" is "DEFAULT" and the "Name of Associated Seasonal Curve" is "DEFAULT". The "Load Model" is "2.) Constant P and Q, regardless of voltage.". The "Type of Load" section has "(P,Q)" selected. The parameters are: P: 450, Q: 225, S: 0, PF: 0, VA conn.: 0, Wh: 0, PF: 0. A note at the bottom states: "NOTE: Power Factor convention: + for Lagging, - for Leading". Buttons for "Active Daily Load Curve...", "Active Seasonal Load Curve...", "Edit Terminals...", "OK", and "Cancel" are present.

Figure 2.
Load dialog box.

Features and Detailed Description

EFFICIENCY FEATURES

The V-GRAPH program contains many built-in features to maximize user efficiency. For example, you may create a library of common devices (e.g., line codes) to be used by several circuits.

You can define a subset of buses or branches for which to display Power Verdict analysis results. You may also define an additional subset of the type of results to display. For example, of the possible fault current types you may wish to view only three-phase fault currents.

Default name prefixes may also be customized to correspond to company standards. This may eliminate the need to modify names during device installation.

CUSTOMIZABLE OUTPUT

In addition to allowing clipboard copying of an entire one-line, the V-GRAPH program allows you to specify selected regions of the one-line to copy. This may be useful if a particular region of the power system is to be summarized in a report.

The optional header of a one-line diagram printout is user-definable. A timestamp of printing is also optional.

DATA VERIFICATION

All of the device dialog boxes contain a validation system. Entered data is checked against database minimum and maximum allowed values. The program also checks for pre-existing device names and warns of naming conflicts.

ADVANTAGES

- Centralized access to a common database greatly facilitates modeling and studying electrical power systems.
- The program takes full advantage of Windows memory management capabilities.
- A one-line diagram for use by a Power Verdict Series program can be quickly constructed.
- A library of devices can be maintained within the program, so you don't have to reenter the same data.
- One-line diagrams can be pasted into standard Windows spreadsheet or word processing applications.
- Extensive context-sensitive on-line help is available.
- Custom symbols can be created.

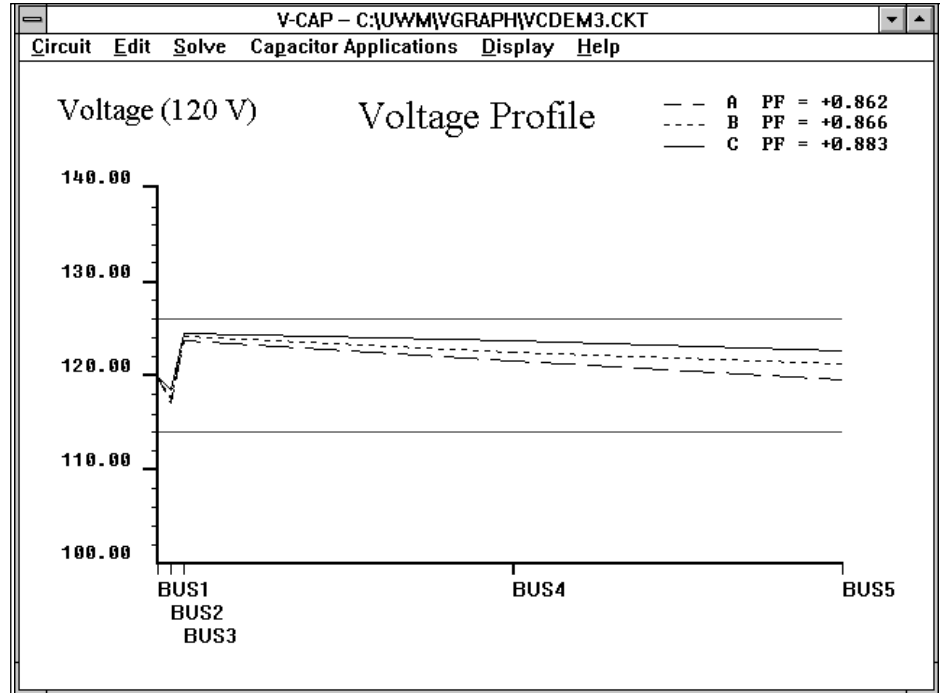

Figure 3.
V-CAP analysis using V-GRAPH circuit.

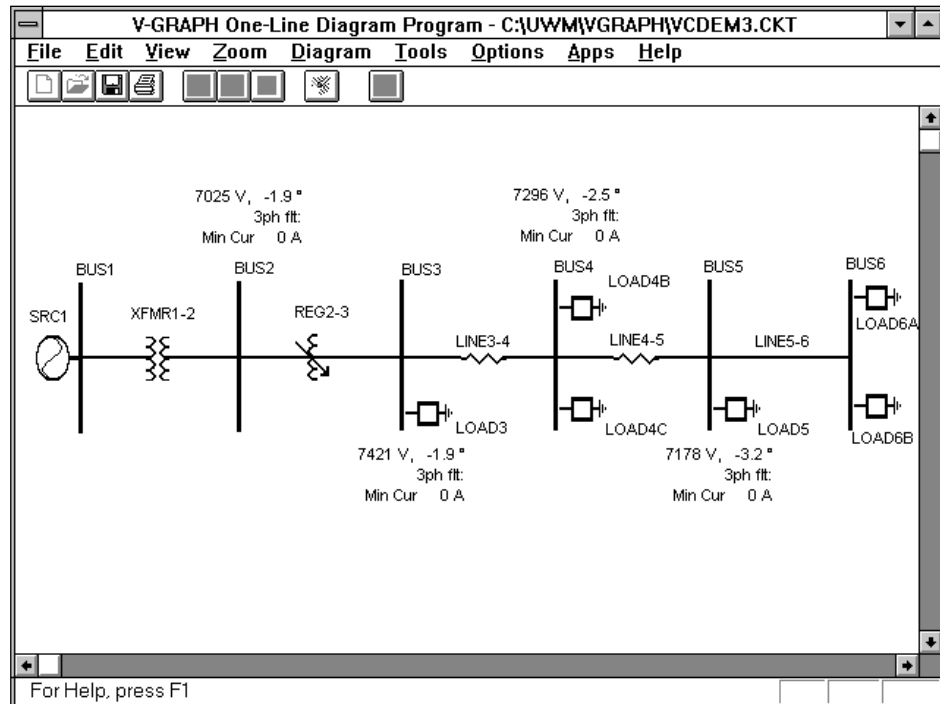

Figure 4.
V-CAP bus results in V-GRAPH.

APPLICATIONS

- In addition to serving as an interface to the database, the V-GRAPH program can also display the results from all Power Verdict programs.
- Very large power systems can be modeled.
- By switching the display mode from Editing to Analysis any results associated with bus or branch devices may be viewed. Results may be understood more quickly than by examining large tables of data.
- Results from Power Verdict programs can be displayed including losses, currents, power flows and voltages (magnitudes and angles).
- Results can also be displayed in tabular form, similar to those in spreadsheet programs.
- Study reports can be generated quickly.

ADDITIONAL FEATURES

- Print Preview allows you to view the appearance of the diagram before it is printed.
- Print Setup allows you to change printer connections within the program.
- Intuitive toolbars invoke various drawing modes.
- Auto Save periodically saves the active one-line diagram.
- An Undo function provides recovery from accidental deletions.
- The Scrolling and Zoom features allow you to select portions of the active one-line diagram to display in the view window.

OTHER ANALYSIS

PRODUCTS AND SERVICES

V-GRAPH software is part of a complete distribution analysis package offered by Cooper Power Systems. Related products include:

- Power Verdict Series of interactive software developed by Systems Engineering to analyze and troubleshoot utility and industrial systems.
- Engineering Workshops.
- Power System Studies.
- Transient, Harmonic, and Voltage Flicker Measurements.
- Technical Publications.

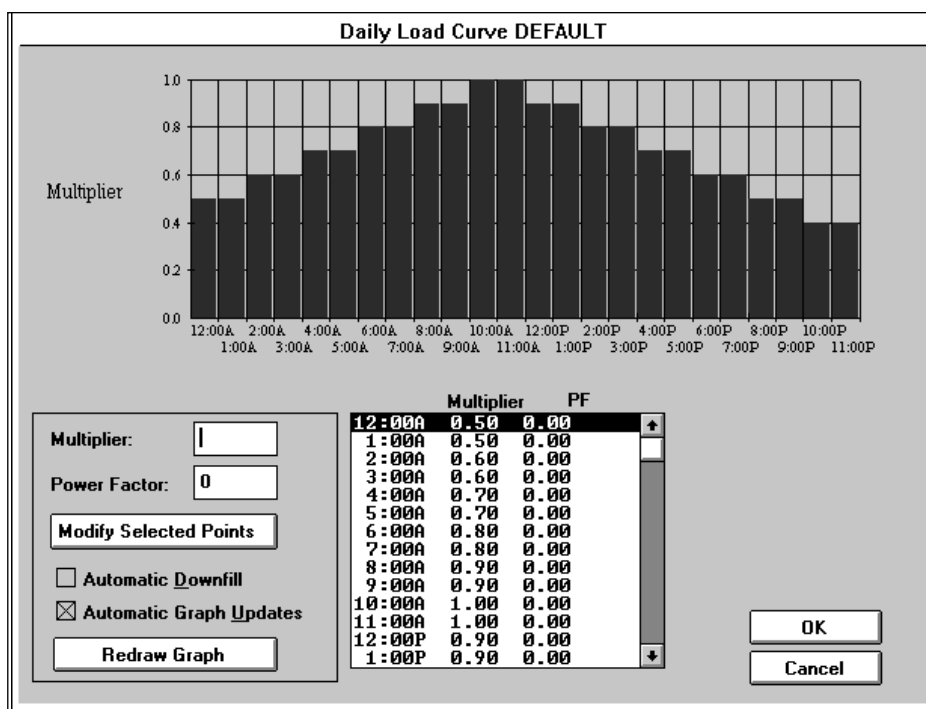

Figure 5.
Load curve editing.

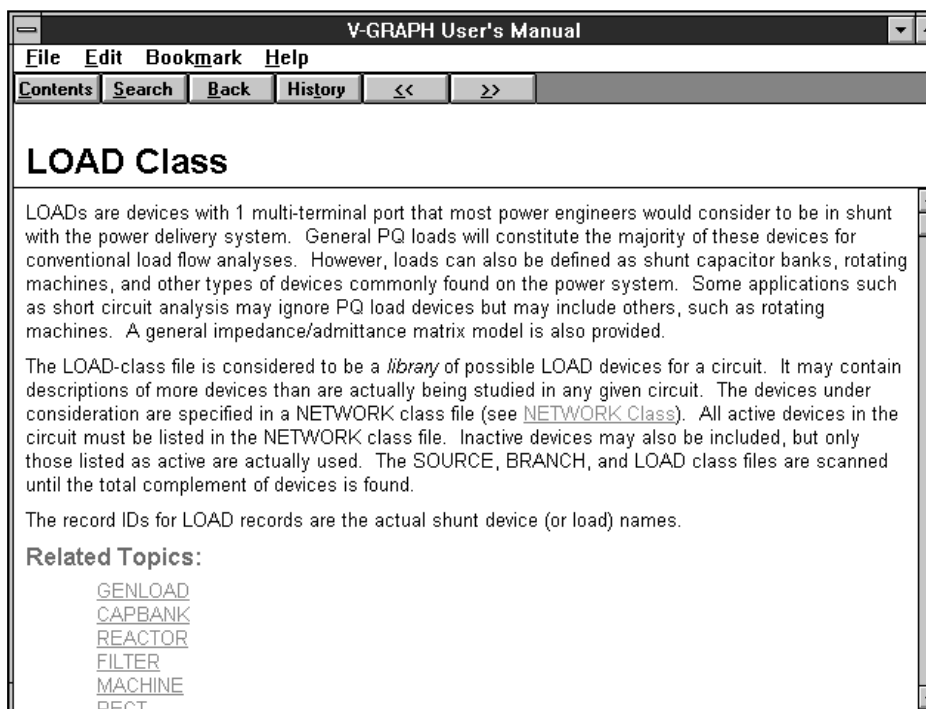

Figure 6.
Context sensitive help for load class.

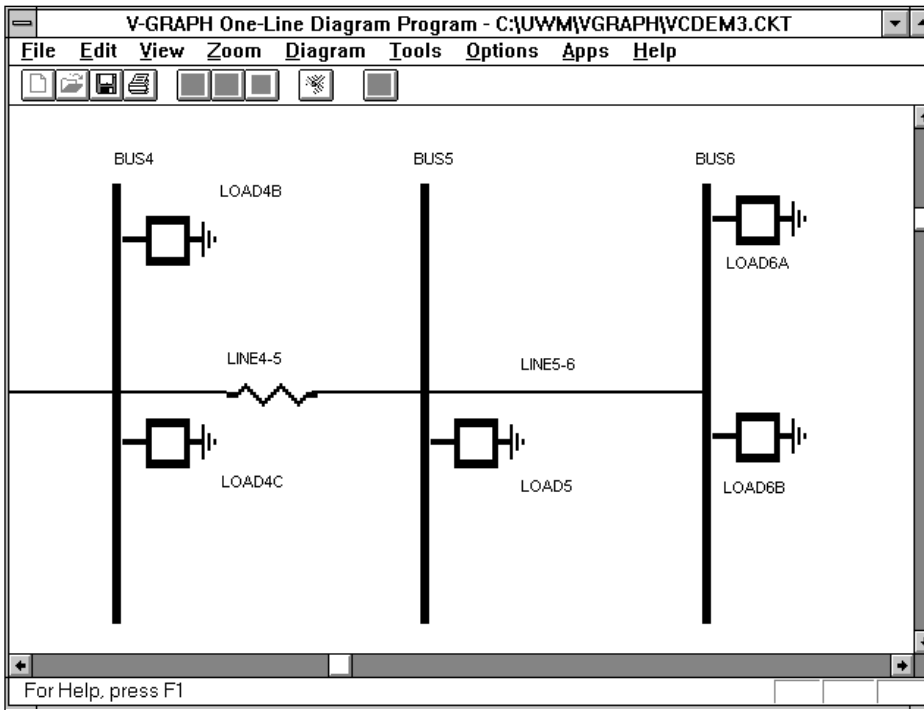

Figure 7.
V-GRAPH scaling.

Other software in the Power Verdict Series includes:

- V-CAP™, The Circuit Analysis Verdict™, regulator and capacitor application program.
- V-PRO®, The Protection Verdict™, graphics-oriented overcurrent protection coordination program.
- V-NET™, The Network Fault Verdict™, for complete fault analysis.
- V-FLOW™, The Power Flow Verdict™, for utility and industrial system network or radial power flows.
- V-HARM™, The Harmonics Verdict™, to calculate harmonic levels that replicate field tests and measurements.

For more information contact your Cooper Power Systems representatives or:

Systems Engineering Group
Thomas A. Edison Technical Center
11131 Adams Rd., P. O. Box 100
Franksville, WI 53126-0100
(414) 835-2921
(414) 835-1544 (Fax)

The screenshot shows the "2- and 3-Winding Transformer" dialog box. The "Device Name" is "XFMR1-2". The parameters are organized into columns for Primary, Secondary, and Tertiary windings. The Primary winding has a voltage of 34.5 kV, impedance of 0.7% and 7%, and a BIL of 125 kV. The Secondary winding has a voltage of 12.47 kV, impedance of 0.35% and 35%, and a BIL of 30 kV. The Tertiary winding has a voltage of 0 kV, impedance of 0.35% and 35%, and a BIL of 30 kV. The dialog also includes options for Wdg Conn (Wye or Delta), Neutral Impedance, KVA Ratings, and Cooling Types. The "Number of Tap Ratings" is set to 1. The "OK" and "Cancel" buttons are at the bottom right.

Figure 8.
Transformer code dialog box.



Cooper Power Systems