

Pad-mounted Switchgear

Type MOST Oil-Insulated Switchgear Installation, Operation, and Maintenance Instructions

Service Information
S285-20-1



Figure 1.
Kyle® Type MOST oil-insulated switchgear.

921114KM

Contents

Safety Information	2	Maintenance Information	9
Product Information	3	Maintenance Inspection Procedure	9
Introduction	3	Internal Inspection and Bushing Replacement	9
Acceptance and Initial Inspection	3	Insulating Oil Maintenance	10
Handling and Storage	3	Frequency of Maintenance	10
ANSI Standards	3	Types of Oil Samples	10
Quality Standards	3	Oil Sampling Procedure	10
Product Description	3	Oil Fill Procedure	10
Ratings	5	Oil Testing	11
Installation Procedure	6	General Oil Tests	11
Operation	8	Dissolved Gas Analysis	11
Application	8	Replacement Parts	11
Switch Operating Handle	8	Testing	12
Fuses	8	High Potential Withstand Test	12
Fuse Changeout Procedure	8		



SAFETY FOR LIFE



Cooper Power Systems products meet or exceed all applicable industry standards relating to product safety. We actively promote safe practices in the use and maintenance of our products through our service literature, instructional training programs, and the continuous efforts of all Cooper Power Systems employees involved in product design, manufacture, marketing, and service.

We strongly urge that you always follow all locally approved safety procedures and safety instructions when working around high voltage lines and equipment and support our “Safety For Life” mission.

SAFETY INFORMATION

The instructions in this manual are not intended as a substitute for proper training or adequate experience in the safe operation of the equipment described. Only competent technicians who are familiar with this equipment should install, operate, and service it.

A competent technician has these qualifications:

- *Is thoroughly familiar with these instructions.*
- *Is trained in industry-accepted high- and low-voltage safe operating practices and procedures.*
- *Is trained and authorized to energize, de-energize, clear, and ground power distribution equipment.*
- *Is trained in the care and use of protective equipment such as flash clothing, safety glasses, face shield, hard hat, rubber gloves, shotgun stick, etc.*

Following is important safety information. For safe installation and operation of this equipment, be sure to read and understand all cautions and warnings.

Safety Instructions

Following are general caution and warning statements that apply to this equipment. Additional statements, related to specific tasks and procedures, are located throughout the manual.



DANGER: Hazardous voltage. Contact with hazardous voltage will cause death or severe personal injury. Follow all locally approved safety procedures when working around high- and low-voltage lines and equipment.

G103.3



WARNING: Before installing, operating, maintaining, or testing this equipment, carefully read and understand the contents of this manual. Improper operation, handling, or maintenance can result in death, severe personal injury, and equipment damage.

G101.0



WARNING: This equipment is not intended to protect human life. Follow all locally approved procedures and safety practices when installing or operating this equipment. Failure to comply can result in death, severe personal injury, and equipment damage.

G102.1



WARNING: Power distribution equipment must be properly selected for the intended application. It must be installed and serviced by competent personnel who have been trained and understand proper safety procedures. These instructions are written for such personnel and are not a substitute for adequate training and experience in safety procedures. Failure to properly select, install, or maintain power distribution equipment can result in death, severe personal injury, and equipment damage.

G122.2

Hazard Statement Definitions

This manual may contain four types of hazard statements:



DANGER: Indicates an imminently hazardous situation which, if not avoided, will result in death or serious injury.



WARNING: Indicates a potentially hazardous situation which, if not avoided, could result in death or serious injury.



CAUTION: Indicates a potentially hazardous situation which, if not avoided, may result in minor or moderate injury.

CAUTION: Indicates a potentially hazardous situation which, if not avoided, may result in equipment damage only.



PRODUCT INFORMATION

Introduction

Service Information S285-20-1 provides installation instructions, operation information, testing instructions, and maintenance procedures for Kyle® Type MOST oil-insulated switchgear.

Read This Manual First

Read and understand the contents of this manual and follow all locally approved procedures and safety practices before installing, operating, or maintaining this equipment.

Additional Information

These instructions do not claim to cover all details or variations in the equipment, procedures, or process described, nor to provide directions for meeting every possible contingency during installation, operation, or maintenance. When additional information is desired to satisfy a problem not covered sufficiently for the user's purpose, please contact your Cooper Power Systems sales engineer.

Acceptance and Initial Inspection

Type MOST switchgear is completely assembled, tested, and inspected at the factory. The switchgear is filled to the correct level with insulating oil. It is in good condition when accepted by the carrier for shipment.

1. Upon receipt, inspect the unit thoroughly for damage and loss of parts or oil incurred during shipment. If damage or loss is discovered, file a claim with the carrier immediately.
2. Check for oil leakage and tighten any bolts that may have loosened during shipment.

Handling and Storage

The switchgear should remain on its shipping pallet until it is installed. When handling the switchgear, always use a fork truck that has adequate lifting capacity and forks that extend the entire length of the pallet. Improper handling can cause damage to the switchgear.

If the switchgear is to be stored for any appreciable time before installation, provide a clean, dry storage area. Be careful during handling and storage to minimize the possibility of mechanical damage. Do not stack other material on the switchgear.

ANSI Standards

MOST switchgear is designed and tested in accordance with ANSI standards C57.12.28, C37.72 and ANSI standard 386.

Quality Standards

The Quality System at the Cooper Power Systems Kyle

Distribution Switchgear plant is certified to the ISO 9001 Standard.

Product Description

Type MOST oil-insulated switchgear provides convenient load switching for 15-, 25-, and 35 kV underground systems. MOST switchgear is designed for outdoor mounting on a concrete pad. Power is fed to and from the switchgear from underground, through openings in the pad.

Deadfront construction minimizes the high voltage safety hazards for both the operator and the general public.

Type MOST switchgear employs oil as the insulation medium to provide a compact, low-profile installation.

R-Temp® dielectric fluid may be provided instead of insulating oil, if specified at the time of order. Refer to manufacturer's instructions for specifications and ASTM-approved testing procedures.

CAUTION: The use of R-TEMP® and Envirotemp® FR3™ dielectric fluids is limited to a minimum operating temperature of 0° C (32° F).
T307 .0

MOST switchgear can be used for both utility and industrial applications and can be equipped with a variety of fusing options to meet distribution system protection requirements.

Switch Operation

Kyle® MOST switchgear utilizes single-phase and three-phase, gang-operated loadmake/loadbreak oil sectionalizing switches.

Positive position indicators are provided. A spring-loaded actuator provides loadbreak operation and positive latching through all positions, independent of the speed at which the operating handle is turned. The side-mounted switch can be operated by a shotgun stick or an optional manually operated T-handle. Front-mounted switches are optional and must be operated with a shotgun stick.

Four switch designs (shown in Figure 4) are available: two-position open/close, four-position selector blade, four-position "V" blade, and four-position "T" blade. The "V" and "T" blade designs perform the function of three separate open/close switches. All switch operations are indicated on a single switch handle.

Bushings

If 600-amp deadbreak aluminum type bushings are furnished, they conform to ANSI standard 386.

200-amp interfaces are provided as either 200-amp bushing wells or 200-amp one-piece bushings; both conform to ANSI standard 386.

Bushings are mounted in-line and located a minimum of 24 inches above the pad.

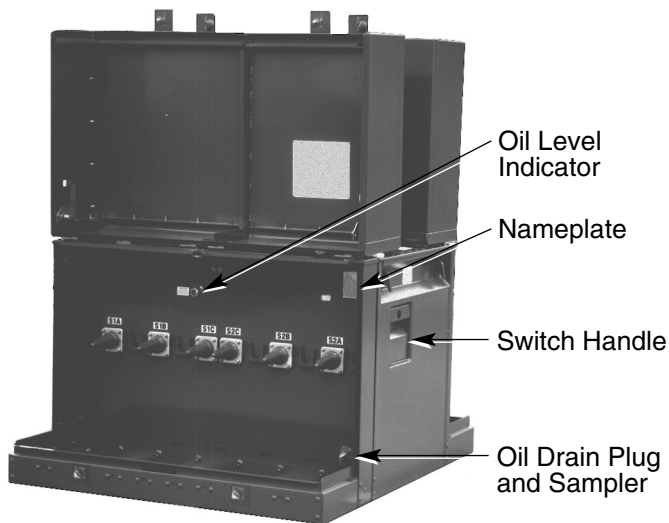

Figure 2.
Source-side switch components.

921116KM

person. Cabinet style doors can also be provided as an option. Both source and tap doors can be fully open at the same time. Each door has a floating lock pocket with padlock provisions and pentahead silicon bronze door bolt.

Tank construction is of 10-gauge steel, and doors are made of 12-gauge steel. Recessed lifting provisions are provided at each corner of the tank for a balanced lift.

Padlocking Provisions

Provisions are included for padlocking the cabinet in order to prevent unauthorized door opening. The cabinet must be locked at all times to prevent accidental contact with hazardous voltage.

Standard Features

Standard features include an oil level indicator on each front plate, automatic pressure-relief valve, operation one-line diagrams on the doors, oil fill plug, oil drain and sampler, and a standoff bracket for each bushing. Standard grounding provisions include a 1/2-13 UNC stainless steel ground nut for each bushing.

Finish

MOST switchgear is finished in a green color which conforms to Munsell 7GY 3.29/1.5 Green.

The coating conforms to the following specifications: ANSI standard C57.12.28, ASTM B1117 1000-hour 5% salt spray corrosion test, ASTM D2247 1000-hour humidity test, ASTM G53 500-hour ultraviolet accelerated weathering test, and ASTM D2794 impact test.

Nameplate

Prior to installation, be sure to check the switchgear nameplate (shown in Figure 2), to verify that the voltage and current ratings are correct for the system on which the switchgear is to be installed.

Weight

The weight of the switchgear is shown on the nameplate. Be sure that lifting equipment used is rated sufficiently to safely handle the switchgear.

Switch Operating Handle

The Type MOST switchgear is equipped with a side-mounted loadbreak switch (shown in Figure 2). The side-mounted switch has a positive position indicator and is operated by a shotgun stick or by an optional hand-operable T-handle.

If the switch is equipped with the optional front-mounted operating handle, it must be operated with a shotgun stick.

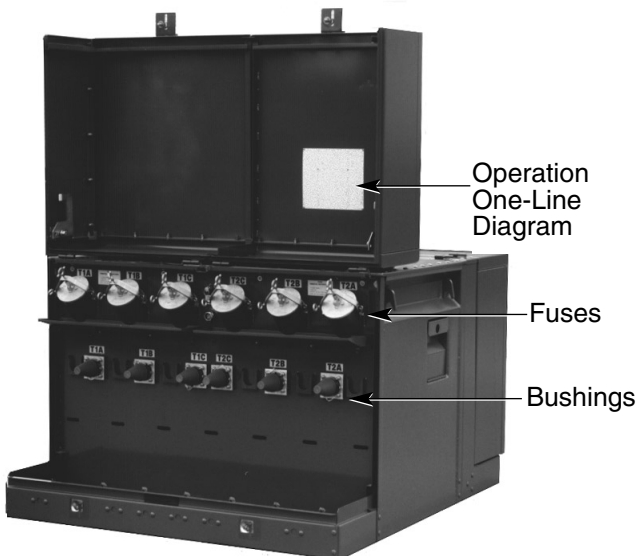

Figure 3.
Tap-side switch components.

921115KM

Cabinet Construction

The deadfront, tamper-resistant construction of low-profile MOST switchgear makes it suitable for operation in areas subject to excessive moisture, occasional flooding and blowing snow. Cabinets meet the enclosure security requirements of ANSI standard C57.12.28.

Swing-up doors are provided with door stays and fitted with stainless steel hinges. On units wider than 46 inches, split doors are provided to allow easy operation by one

⚠ WARNING: Hazardous voltage. Never rely on the open position of the operating handle or the contact position indicator; it does not ensure that the line is de-energized. Follow all locally approved safety practices. Failure to comply can result in contact with high voltage, which will cause death or severe personal injury.

G123.1

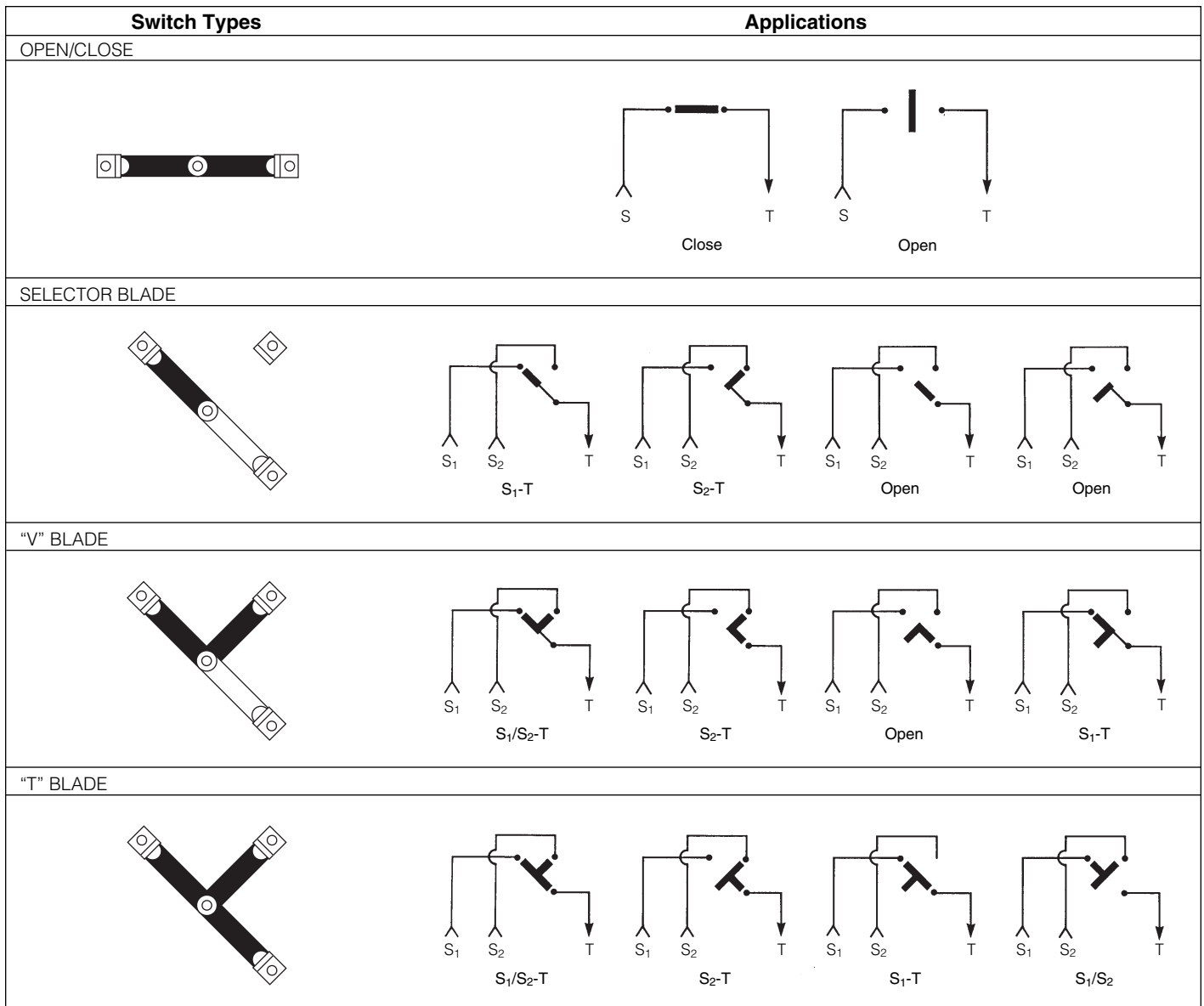

Switch center is pivot point.
 Black segments of blade rotate.
 White segments are stationary.

Figure 4.
Switch positions for open-close, selector blade, "V" blade, and "T" blade switches.

RATINGS

TABLE 1
Electrical Ratings

Nominal Voltage	5 kV	15 kV	25 kV	35 kV
Maximum Design Voltage, kV	15.5	15.5	27	38
BIL, kV	95	95	125	150
1-Minute Withstand (60 Hz) Switch and Terminators, kV	34	34	40	50
Continuous Current (max), amps	600	600	300	200
Load Switching, amps	600	600	300	200
Momentary Current 10 cycles (asym.), amps ...	16,000	16,000	16,000	16,000
2 Sec. (sym.), amps	10,000	10,000	10,000	10,000
3 Shot Make and Latch (asym.), amps	16,000	16,000	16,000	9,600
Interrupting Rating (kA)*	50	50	20 - 50	12.2 - 50

*Interrupting rating for fused units depends on the selected fuses and the application voltage.

INSTALLATION PROCEDURE

WARNING: This equipment is not intended to protect human life. Follow all locally approved procedures and safety practices when installing or operating this equipment. Failure to comply can result in death, severe personal injury, and equipment damage.

G102.1

1. Check the oil level. Make sure the oil in the switchgear tank is at the proper level by checking the oil level indicator on the front plate. Two-sided units have oil level indicators on both source-side and tap-side front plates. Make sure both are at the proper level.

2. Test the oil dielectric strength. If the switchgear has been stored for some time or is being relocated, perform a dielectric test on the oil in accordance with ASTM-approved testing procedures.

Note: R-Temp[®] dielectric fluid may be provided instead of insulating oil, if specified at the time of order. Refer to manufacturer's instructions for specifications and ASTM-approved testing procedures.

CAUTION: The use of R-TEMP[®] and Envirotemp[®] FR3[™] dielectric fluids is limited to a minimum operating temperature of 0° C (32° F).

T307 .0

CAUTION: This equipment relies on oil to provide electrical insulation between components. The dielectric strength of the oil must be checked on a regular basis, as part of the routine maintenance inspection, to ensure that it is at or above minimum dielectric requirements. Use of this equipment with insulating oil that does not meet minimum requirements can result in internal flashovers that will damage the equipment and can cause personal injury.

G107.2

- A.** On new equipment, the oil must have a minimum dielectric strength of 26 kV.
- B.** If the dielectric strength of the oil is less than 26 kV, filter the oil to restore its dielectric strength to acceptable minimum level.
- C.** For additional information on oil specifications and tests, refer to *Reference Data R280-90-1* and to the oil testing procedures on page 10 of this manual.

3. Check the nameplate ratings. Make sure that the ratings shown on the switch nameplate are correct for the planned installation.

CAUTION: Follow all locally approved safety practices when lifting and mounting the equipment. Use the lifting lugs provided. Lift the unit smoothly and do not allow the unit to shift. Improper lifting can result in equipment damage.

G106.2

CAUTION: Equipment damage. Never place jacks, tackle or other attachments under the unit for the purpose of lifting. Failure to comply will result in damage to the equipment.

T240.0

4. Mount the switchgear on the concrete pad.

- A.** The switchgear must be installed on a level concrete pad or structure strong enough to support the weight.
- B.** The switchgear must be hoisted only by the recessed lifting provisions provided at the four corners of the tank. Suitable lifting straps must be used to prevent damage to the switchgear housing.
- C.** Anchor the switchgear. The switchgear must be anchored to the concrete pad using the mounting cleats provided or using other suitable mounting hardware.

WARNING: Hazardous voltage. Solidly ground all equipment. Failure to comply can result in death, severe personal injury, and equipment damage.

T223.2

5. Ground the switchgear. Switchgear must be adequately grounded. Install a permanent low-resistance ground connection to the switchgear tank. Grounding provisions are provided near the bottom of the tank.

CAUTION: Equipment Misoperation. Always use compatible fuses. Follow all locally approved operating practices whenever changing fuses. Wet-well fuse assemblies must be refused and operated in accordance with the instructions provided by the fuse manufacturer. Failure to install the proper fuse can result in switchgear misoperation, equipment damage, and personal injury.

T260.0

6. Assemble and install fuses. If the switchgear is equipped with fuses, be sure that the fuses are rated correctly for the installation and that they are properly installed. Further verify that the fuses are compatible with the wet-well fuse holder(s) supplied with the switchgear. Refer to Figure 5 to ascertain fuse/wet-well fuse holder compatibility.

Note: Fuses should be applied on solidly grounded wye systems only. Consult factory for fuse application on delta systems.

7. Make the high-voltage line connections.

- A.** Prior to making connections, make sure that the source-side and tap-side cable elbows are correctly identified and that the switchgear unit is oriented correctly for the installation. The source leads must connect to the source bushings of the unit and tap leads must connect to the tap bushings of the unit.



- B. Refer to the operation one-line diagrams located inside the doors of the switchgear and make only those elbow connections shown. The voltage and current ratings shown on the nameplate must be correct for the planned installation.
- C. All cables not in use must be properly isolated from all other leads. Unused leads must be parked on standoff insulators or properly grounded using an elbow grounding kit.
- D. All bushings not in use must be insulated with properly rated isolating caps. It is also recommended that bushing elbow studs be pre-installed for future use. The studs must be torqued into place and this is best done before the equipment is energized.

IMPORTANT: Do not use the red shipping covers on unused bushings. They are not designed for permanent use on energized equipment.

8. Close and lock the doors of the switchgear in order to prevent unauthorized access and accidental contact with high voltage lines.

Fuse/Wet-well Fuse Holder Compatibility		
Fuse Rating	Nominal Fuse Length (in)	Standard Wet-well Holder Assembly
15 kV	19	3437322C01M
25 kV	21	3437322C05M*
35 kV	21	3437322C05M*

*19" fuse assemblies may be installed in 3437322C05M assemblies by using part number 348230A01 mounting adapters. A quantity of two mounting adapters per fuseholder are required.

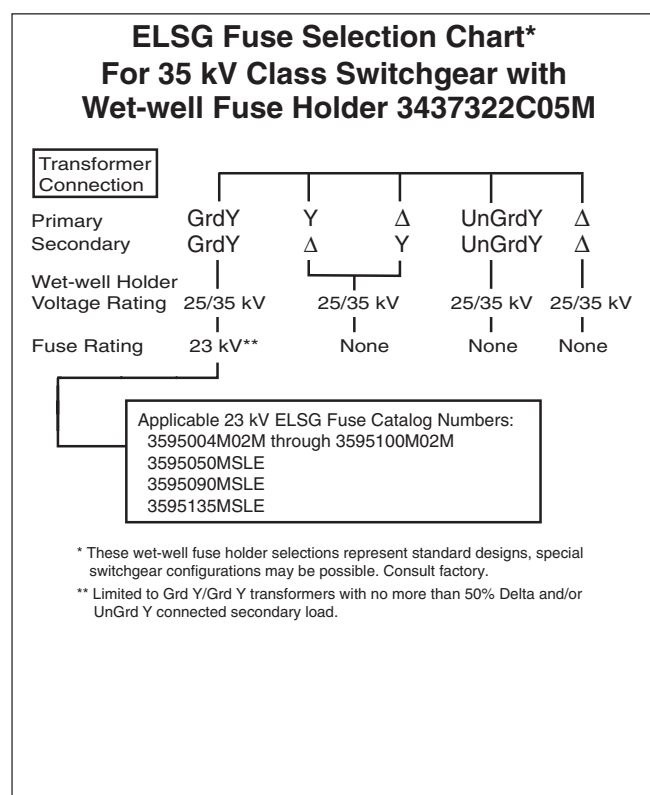
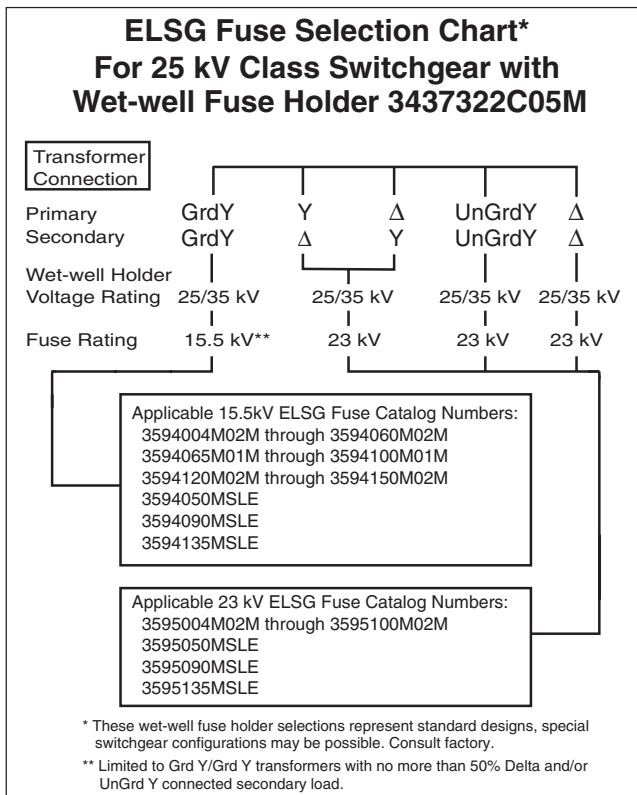
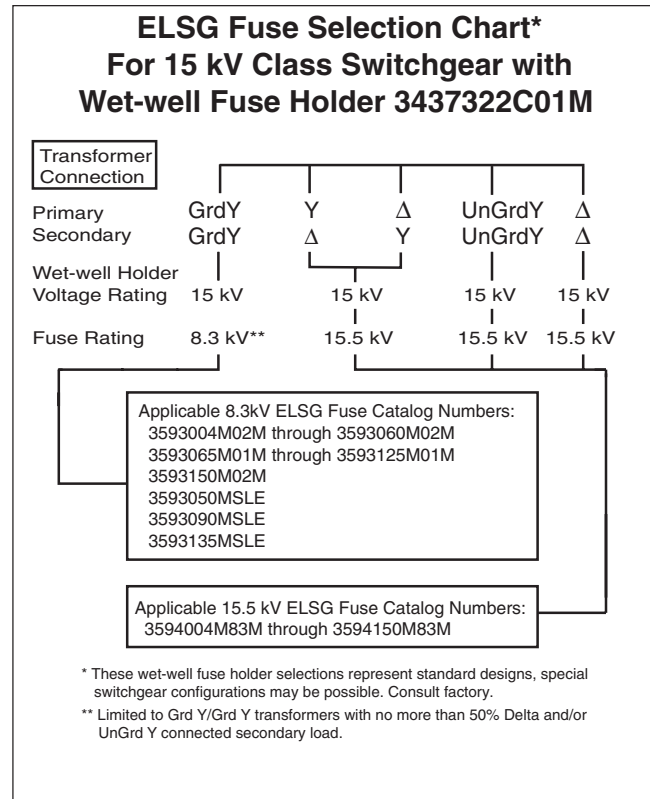





Figure 5.
Fuse Holder/Fuse Compatibility Charts.

OPERATION

 **DANGER:** Hazardous voltage. Contact with hazardous voltage will cause death or severe personal injury. Follow all locally approved safety procedures when working around high- and low-voltage lines and equipment. G103.3

 **WARNING:** Hazardous voltage. Never rely on the open position of the operating handle or the contact position indicator; it does not ensure that the line is de-energized. Follow all locally approved safety practices. Failure to comply can result in contact with high voltage, which will cause death or severe personal injury. G123.1

 **WARNING:** Do not operate this equipment out of oil. Oil is the electrical insulating medium within this equipment; operation out of oil will result in internal flashovers that will damage the equipment and can cause death or severe personal injury. G104.2

Application

This switchgear must only be applied within its specified ratings. At no time should the continuous total load exceed the ratings shown on the nameplate.

The switchgear must always be filled to the correct level with insulating oil or R-Temp® dielectric fluid.

CAUTION: The use of R-TEMP® and Envirotemp® FR3™ dielectric fluids is limited to a minimum operating temperature of 0° C (32° F). T307.0

Switch Operating Handle

 **WARNING:** Hazardous voltage. Always use a shotgun stick when working with this equipment. Failure to do so could result in contact with high voltage, which will cause death or severe personal injury. G108A.0

The side-mounted loadbreak switch operating handle (Figure 2) can be operated either by a shotgun stick or with the accessory manual T-handle. Always follow locally approved operating practice when working with this equipment.

Each opening and closing of the loadbreak switch requires a full movement from CLOSED to OPEN or OPEN to CLOSED. Do not reverse the movement in between each full movement, as it can cause the mechanism to bind and eventually fail.

If the unit is equipped with a front-mounted switch operating handle, it must be operated with a shotgun stick.

Refer to the *Product Information* section and Figure 4 of this manual for further information on the switching system.

Fuses

 **CAUTION:** Equipment Misoperation. Always use compatible fuses. Follow all locally approved operating practices whenever changing fuses. Wet-well fuse assemblies must be refused and operated in accordance with the instructions provided by the fuse manufacturer. Failure to install the proper fuse can result in switchgear misoperation, equipment damage, and personal injury. T260.0

Follow locally approved operating practice whenever changing fuses. Verify that the replacement fuses are compatible with the fuse holder(s) supplied with the switchgear. Refer to Figure 5 to ascertain fuse/wet-well fuse holder compatibility.

Note: Fuses should be applied on solidly grounded wye systems only. Consult factory for fuse application on delta systems.

Fuse Change-out Procedure

 **WARNING:** Hazardous voltage. This equipment must be de-energized and grounded prior to conducting any maintenance, oil sampling or oil filling procedures. Failure to comply can result in death or severe personal injury. T239.1

1. De-energize and properly ground the switchgear.
2. Remove the loadbreak elbow and park the elbow on the parking stand.
3. Cap the bushing with an insulated bushing cap. If the unit is not equipped with drip shields, cover the bushings and elbows to prevent oil from dripping on them.
4. Follow the instructions provided with the replacement fuses. Remove the expended fuse and install the replacement fuse.
5. Remove the insulating cap from the bushing. Remove the loadbreak elbow from the parking stand and re-install the elbow on the bushing.

MAINTENANCE INFORMATION

 **CAUTION:** This equipment requires routine inspection and maintenance to ensure proper operation. If it is not maintained, it can fail to operate properly. Improper operation can cause equipment damage and possible personal injury.

G105.1

 **CAUTION:** This equipment relies on oil to provide electrical insulation between components. The dielectric strength of the oil must be checked on a regular basis, as part of the routine maintenance inspection, to ensure that it is at or above minimum dielectric requirements. Use of this equipment with insulating oil that does not meet minimum requirements can result in internal flashovers that will damage the equipment and can cause personal injury.

G107.2

Type MOST switchgear is a deadfront design. All live parts are contained within the sealed tank enclosure. A routine maintenance inspection program is required to ensure proper operation.

It is necessary to establish and maintain a regular schedule for sampling and testing the insulating oil to ensure proper dielectric strength and to maintain the proper oil level in the device.

Maintenance Inspection Procedure

The Type MOST switch must be de-energized, grounded, and removed from service before conducting any maintenance, oil sampling, or oil filling procedures.

 **WARNING:** Hazardous voltage. This equipment must be de-energized and grounded prior to conducting any maintenance, oil sampling or oil filling procedures. Failure to comply can result in death or severe personal injury.

T239.1

- 1. De-energize and properly ground the switch.**
- 2. Reduce the internal tank pressure to 0 PSIG.** The switch is equipped with a pressure relief valve that opens at 5 PSIG and closes at 3 PSIG. To relieve internal tank pressure, pull the ring on the pressure relief valve, to reduce the pressure to 0 PSIG.
- 3. Check the oil level.** Make sure the oil in the switch tank is at the proper level by checking the oil level indicator on the front plate (Check the oil level indicators on both front plates on two-sided units).
- 4. Inspect the unit for damage.** Check for unusual wear of the paint finish. Check switch operating handle, bushings, elbows, and fusing. Make sure connections are secure. Check for oil leaks or other unusual or abnormal indications of wear or abuse. Make sure that the cabinet doors will lock securely. Record any unusual conditions.

Internal Inspection and Bushing Replacement

If internal damage is suspected, or if the switch must be opened for inspection, the following procedure is recommended.

 **WARNING:** Hazardous voltage. This equipment must be de-energized and grounded prior to conducting any maintenance, oil sampling or oil filling procedures. Failure to comply can result in death or severe personal injury.

T239.1

- 1. De-energize and properly ground the switchgear.**
- 2. Draw an oil sample,** using the drain plug with sampler at the bottom of the tank. If moisture is found in the tank, replace the oil with clean, dry insulating oil after maintaining the unit.
- 3. Clean off the tank cover.** Take appropriate precautions to keep dirt, moisture, and any other foreign matter from entering the tank and contaminating the insulating oil.
- 4. Remove the tank cover.**
- 5. Inspect for internal damage.** Check inside the switchgear for broken leads and loose parts. If any bushings, switches, or fuseholders are damaged, repair as required.
- 6. Bushing repairs.** The bushings can be changed through the tank cover.
 - A. Lower the oil level** as needed to make repairs. Store the drained oil according to locally approved procedures.
 - B. Disconnect the internal cables and leads.**
 - C. Unbolt the external steel clamps** from the front plate and replace any damaged bushings, bushing wells, fuseholders, or switches with new parts and a new gasket. Be sure to position the gasket so that it will seal properly.
- 7. Replace tank cover.** Secure with original hardware. The cover gasket may be reused if it is not damaged.
- 8. Re-fill with insulating oil.** Refer to the *Oil Sampling and Testing Procedures* in this manual and make sure that the unit is properly filled to the 77° F (25°C) oil fill level with clean, dry insulating oil.
- 9. Close and lock the doors** of the switchgear, after repairs are complete, in order to prevent unauthorized access and accidental contact with high voltage lines.

Insulating Oil Maintenance

CAUTION: This equipment relies on oil to provide electrical insulation between components. The dielectric strength of the oil must be checked on a regular basis, as part of the routine maintenance inspection, to ensure that it is at or above minimum dielectric requirements. Use of this equipment with insulating oil that does not meet minimum requirements can result in internal flashovers that will damage the equipment and can cause personal injury. G107.2

To assure trouble-free operation of this equipment, a regular schedule of oil testing and oil maintenance should be followed. A routine oil testing and maintenance schedule is necessary to monitor changes that occur in the oil as a result of normal operation and to detect abnormal conditions that may occur.

Maintaining a record of this test data will help in assessing the condition of the oil over time.

Note: R-Temp® dielectric fluid may be provided instead of insulating oil, if specified at the time of order. Refer to manufacturer's instructions for specifications and ASTM-approved testing procedures.

CAUTION: The use of R-TEMP® and Envirotemp® FR3™ dielectric fluids is limited to a minimum operating temperature of 0° C (32° F). T307 .0

Frequency of Maintenance

The insulating oil should be initially tested within two years after the installation of the equipment. That test will yield information required to establish a benchmark reference for observing trends in the unit's normal operation and to diagnose any fault conditions that may be present.

Oil switchgear should then be maintained at least every three years. The scheduled maintenance should include a physical inspection of the unit, an oil level check, and oil testing as described in the *Oil Testing* section of this manual.

Types of Oil Samples

The unit must be de-energized before withdrawing an oil sample. Withdrawing an oil sample from a unit that has critically low oil level could result in flashover and unit failure when the unit is re-energized. Never energize this equipment without ensuring that it is filled to the proper oil level with clean, dry insulating oil.

The oil sampling procedure requires that two types of oil samples be taken.

- 1. A bulk oil sample** to be used for general oil tests. Approximately one quart (one liter), taken in accordance with ASTM D923 (latest revision), is required.
- 2. A "gas-tight" oil sample**, taken in accordance with ASTM D3613 (latest revision), for diagnosis and fault gas analysis.

Oil Sampling Procedure

Use the following oil sampling procedure in order to prevent contamination of the samples taken:

WARNING: Hazardous voltage. This equipment must be de-energized and grounded prior to conducting any maintenance, oil sampling or oil filling procedures. Failure to comply can result in death or severe personal injury. T239.1

1. De-energize the switchgear prior to oil sampling.
2. Never collect an oil sample immediately after oil has been added. A stabilization period of 96 hours is required prior to sampling.
3. Never sample oil during inclement weather (rain, sleet, snow). The oil sample could be contaminated by moisture.
4. Always use the drain plug and sampler, located near the bottom of the front plate, to collect oil samples.
5. Use only approved oil-resistant materials, such as nitrile rubber or silicone tubing for sampling the oil. Use of other materials can result in contamination of the sample.
6. Be careful to prevent contamination of the oil sample from foreign material such as dirt, dust, chemicals, etc. in oil carrying and holding apparatus such as oil cans, transfer tubes, syringes, etc.
7. Upon completion of the sampling, re-check the oil level and add oil if required.

Oil Fill Procedure

The oil level indicator sight gauge on the front plate of the switchgear provides a convenient method to check the oil level. The indicator provides the correct level for oil at 77° F (25° C).

If the oil level is low, use the following procedure to add dry mineral insulating oil to fill the unit to the correct level:

1. De-energize the unit prior to oil filling.
2. Use only insulating oil that complies with ASTM D3487 (latest revision). The oil must have a minimum dielectric strength of 30 kV when tested per ASTM D877. Never use oil that contains PCB's (Polychlorinated Biphenyls).
3. Use only transfer equipment that uses oil resistant materials for hoses, seals, valves, pumps, etc. Failure to use proper transfer equipment can result in contamination of the oil.
4. When adding oil, use the oil fill plug located on the front plate of the unit.



5. Avoid getting gas bubbles in the oil during oil filling. Gas bubbles in the oil will reduce its dielectric strength.
6. When filling is complete, check the oil level gauge to verify that the oil is filled to the correct level. Allow at least one hour for gas bubbles to dissipate prior to energizing the unit.
7. Replace the oil fill plug and energize the unit.
8. Record the date and the amount of oil needed to re-fill the unit and retain the information with the permanent maintenance record of the unit.

Oil Testing

The oil in this equipment has been tested to meet the requirements of ASTM D3487 and it has been processed to remove moisture and dissolved gases. It must be tested on a regular basis in order to ensure that it meets those requirements.

Two types of oil tests are required to evaluate and maintain the quality of the insulating oil. They are: general oil tests and dissolved gas analysis.

General Oil Tests

The general oil test requirements are taken from those described in **IEEE Standard C57.106-1991**, *IEEE Guide for Acceptance and Maintenance of Insulating Oil in Equipment*. The required oil tests and acceptable limits for service-aged oil are shown in Table 2.

Oil test results that do not meet the requirements may indicate a problem with either the oil or the unit. Contact your Cooper Power Systems Division representative for technical assistance.

TABLE 2
Test Limits for Service-Aged Oil

Oil Test	Method	Requirement
Dielectric Strength	D877	26 kV (minimum)
Acid Number	D974	0.20 mg KOH/g (maximum)
Dissipation Factor	D924	1.0% (maximum)
Interfacial Tension	D971	24 mN/m (minimum)
Moisture Content	D1533	35 ppm (maximum)

Dissolved Gas Analysis

Dissolved gas analysis is a useful technique for diagnosing abnormal conditions and assessing the “normal” condition of oil in oil-filled equipment. The method employed is ASTM D3612 which is used in conjunction with **IEEE C57.104-1987**, *IEEE Guide for the Detection and Determination of Generated Gases in Oil Immersed Transformers and their Relations to the Serviceability of the Equipment*. Table 3 provides recommendations on dissolved gas levels in oil insulated switchgear.

TABLE 3
Dissolved Gas In Insulating Oil Maintenance Chart

Acetylene Level C ₂ H ₂	Total Combustible Gas	Required Action
Less than 35 ppm	Less than 500 ppm	<i>Normal Level</i> Re-sample per routine maintenance schedule.
35 - 50 ppm	500 - 1000 ppm	<i>Caution Level</i> Re-sample at 3 - 6 months to establish trend; maintain oil if gas levels increase to hazardous level.
More than 50 ppm	More than 1000 ppm	<i>Hazardous Level</i> Remove unit from service and maintain the oil.

Replacement Parts

Replacement parts for Kyle® pad-mounted switchgear units are available through the factory Service Department. To order replacement parts, refer to the nameplate and provide the product type, serial number, catalog number, voltage rating, and a description of the part. Contact your Cooper Power Systems Division sales representative for additional information and ordering procedures.

TESTING

All pad-mounted switchgear is carefully tested and adjusted at the factory to operate according to published data. Well-equipped test facilities, a detailed testing procedure, and thoroughly trained personnel assure accurately calibrated equipment. Each unit leaves the factory ready for installation.

Pre-installation testing is not necessary. However, should verification of the dielectric condition of the switchgear be required, the switch can be tested using the following procedure.

High Potential Insulation Level Withstand Test

High potential withstand tests provide information regarding the dielectric condition of the switchgear. Testing is performed at 75% of the rated low-frequency withstand voltage.

Safety Requirements

To prevent accidental contact with high voltage parts, the switchgear and high-voltage transformer must be placed in a suitable test cage and all proper grounding procedures must be observed.



WARNING: Hazardous voltage. The switchgear and high-voltage transformer must be in a test cage or similar protective device to prevent accidental contact with the high-voltage parts. Solidly ground all equipment. Failure to comply can result in death, severe personal injury, and equipment damage. T221.3

With the switch contacts open (switch operating handle in the Open position), perform a hi-pot test for 60 seconds across each phase at the voltages shown in Table 4. The switch should withstand the test voltage and should not load down the source.

TABLE 4
High Potential Withstand Test Voltages

MOST Voltage Rating (kV)	High Potential Test Voltages
15	26.2 kV rms or 37.1 kV dc
25	30.0 kV rms or 42.4 kV dc
35	52.5 kV rms or 74.2 kV dc



KA2048-370 Rev: 03

©2004 Cooper Power Systems, Inc.
Kyle® and R-Temp® are registered trademarks of Cooper Industries, Inc.
IEEE Standard C57.106-1991™ and IEEE Standard C57.104-1987™ are trademarks of the Institute of Electrical and Electronics Engineers, Inc.

COOPER Power Systems

1045 Hickory Street
Pewaukee, WI 53072
www.cooperpower.com