

Padmounted Switchgear

Type VFI Fault Interrupter with Tri-Phase Control Single-Phase Trip to Three-Phase Conversion Kit KPA111 Installation Instructions

Service Information
S285-10-5

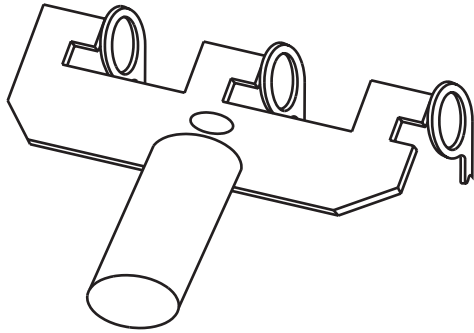

Figure 1.
Ganging tool.

TABLE 1
Conversion Kit KPA111 Parts List *

| Qty. | Part # | Description |
|------|-------------|--------------------------------|
| 1 | SEC-113 | Jumper Connector |
| 1 | P20-29087B1 | Ganging Tool for shotgun stick |

TABLE 2
Conversion Kit KPA111-2 Parts List †

| Qty. | Part # | Description |
|------|-------------|--------------------------------|
| 1 | P20-29087B1 | Ganging Tool for shotgun stick |

* Kit KPA111 for serial number below 3Q9317000
† Kit KPA111-2 for serial number 3Q9317000 and above or beginning with CP57

Contents

| | | | |
|---|----------|---|----------|
| Safety Information | 2 | Quality Standards | 1 |
| Product Information | 1 | Installation and Operation | 3 |
| Introduction | 1 | Circuit Board Modification | 3 |
| Acceptance and Initial Inspection | 1 | Manual Reset | 4 |
| Handling and Storage | 1 | Operation | 4 |

PRODUCT INFORMATION

Introduction

Service Information S285-10-5 Type VFI Fault Interrupter with Tri-Phase Control Single-Phase Trip to Three-Phase Trip Conversion Kit KPA111 Installation Instructions is used to convert Kyle VFI padmount switchgear equipped with a Tri-Phase electronic trip control from single-phase trip to three-phase trip.

Kit KPA111 is applicable for units with a serial number below 3Q9317000 and Kit KPA111-2 is applicable for units with a serial number 3Q9317000 and above or beginning with CP57.

Read This Manual First

Read and understand the contents of this manual and follow all locally approved procedures and safety practices before installing or operating this equipment.

Additional Information

These instructions cannot cover all details or variations in the equipment, procedures, or process described nor provide directions for meeting every possible contingency during installation, operation, or maintenance. For additional information, contact your Cooper Power Systems representative.

Acceptance and Initial Inspection

This product is in good condition at the factory and when accepted by the carrier for shipment.

Upon receipt, inspect the carton for signs of damage. Unpack the kit and inspect it thoroughly for damage incurred during shipment. If damage is discovered, file a claim with the carrier immediately.

Handling and Storage

Be careful during handling and storage of this kit to minimize the possibility of damage. If the kit is to be stored for any length of time prior to installation, provide a clean, dry storage area.

Quality Standards

ISO 9001:2000-certified quality management system



SAFETY FOR LIFE



Cooper Power Systems products meet or exceed all applicable industry standards relating to product safety. We actively promote safe practices in the use and maintenance of our products through our service literature, instructional training programs, and the continuous efforts of all Cooper Power Systems employees involved in product design, manufacture, marketing, and service.

We strongly urge that you always follow all locally approved safety procedures and safety instructions when working around high voltage lines and equipment and support our “Safety For Life” mission.

SAFETY INFORMATION

The instructions in this manual are not intended as a substitute for proper training or adequate experience in the safe operation of the equipment described. Only competent technicians, who are familiar with this equipment should install, operate, and service it.

A competent technician has these qualifications:

- *Is thoroughly familiar with these instructions.*
- *Is trained in industry-accepted high- and low-voltage safe operating practices and procedures.*
- *Is trained and authorized to energize, de-energize, clear, and ground power distribution equipment.*
- *Is trained in the care and use of protective equipment such as flash clothing, safety glasses, face shield, hard hat, rubber gloves, hotstick, etc.*

Following is important safety information. For safe installation and operation of this equipment, be sure to read and understand all cautions and warnings.

Safety Instructions

Following are general caution and warning statements that apply to this equipment. Additional statements, related to specific tasks and procedures, are located throughout the manual.

⚠ DANGER: Hazardous voltage. Contact with hazardous voltage will cause death or severe personal injury. Follow all locally approved safety procedures when working around high- and low-voltage lines and equipment. G103.3

⚠ WARNING: Before installing, operating, maintaining, or testing this equipment, carefully read and understand the contents of this manual. Improper operation, handling or maintenance can result in death, severe personal injury, and equipment damage. G101.0

⚠ WARNING: This equipment is not intended to protect human life. Follow all locally approved procedures and safety practices when installing or operating this equipment. Failure to comply may result in death, severe personal injury and equipment damage. G102.1

⚠ WARNING: Power distribution equipment must be properly selected for the intended application. It must be installed and serviced by competent personnel who have been trained and understand proper safety procedures. These instructions are written for such personnel and are not a substitute for adequate training and experience in safety procedures. Failure to properly select, install or maintain power distribution equipment can result in death, severe personal injury, and equipment damage. G122.2

Hazard Statement Definitions

This manual may contain four types of hazard statements:

⚠ DANGER: Indicates an imminently hazardous situation which, if not avoided, will result in death or serious injury.

⚠ WARNING: Indicates a potentially hazardous situation which, if not avoided, could result in death or serious injury.

⚠ CAUTION: Indicates a potentially hazardous situation which, if not avoided, may result in minor or moderate injury.

⚠ CAUTION: Indicates a potentially hazardous situation which, if not avoided, may result in equipment damage only.

INSTALLATION AND OPERATION

DANGER: Hazardous voltage. Contact with hazardous voltage will cause death or severe personal injury. Follow all locally approved safety procedures when working around high- and low-voltage lines and equipment. G103.3

WARNING: Hazardous voltage. Always use a shotgun stick when working with this equipment. Failure to do so could result in contact with high voltage, which will cause death or severe personal injury. G108A.0

Circuit Board Modification

Remove the access panel of the Tri-Phase control. The VFI operating handles can be in any position.

Kit KPA111 Serial Number Below 3Q9317000

The conversion requires the installation of a jumper connector onto the P2 pin connector of the Tri-Phase control board. The jumper parallels the trip circuits of each phase, so that when a trip is enabled for the flux shift tripper of one phase, all three phases are then tripped.

1. Refer to Figure 2 and locate pin connector P2, which is in the lower right corner of the control board. Install the jumper connector, Part # SEC-113, on P2 as shown. The jumper connector is keyed (one side notched) to allow it to lock in place with P2 when properly installed. Do not force into place.
2. Reinstall the access panel.

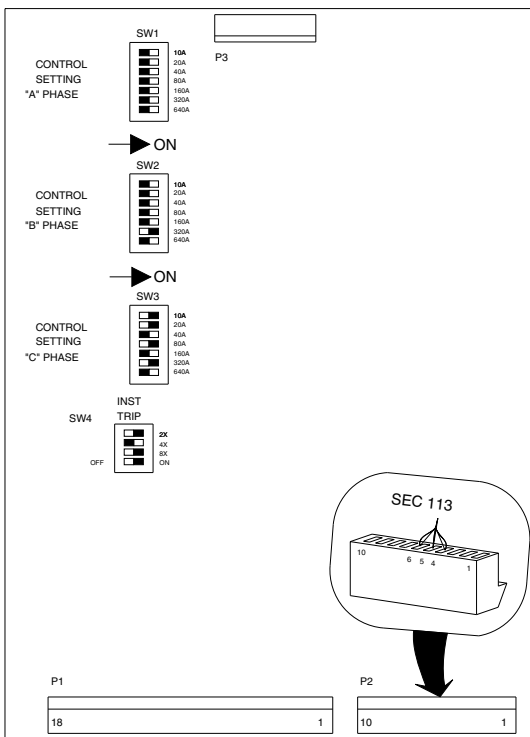

Figure 2.
Installing jumper connector on the control board.

To convert from three-phase trip back to single-phase trip, follow the above procedure except remove the jumper connector from P2 and store in a safe, dry place. Do not apply excessive force to the plastic retainer on P2 when removing the jumper connector. Disengage the connector by grasping both ends of the connector with thumb and index finger and carefully rocking the ends free.

Kit KPA111-2 Serial Number 3Q9317000 and Above or Beginning with CP57

The conversion requires placing the three-phase trip toggle switch in the “ganged” position. In the ganged position, the toggle switch parallels the trip circuits of each phase, so that when a trip is enabled for the flux shift tripper of one phase, all three phases are then tripped.

1. Refer to Figure 3 and locate the three-phase trip toggle switch, which is in the lower right corner of the control board. Place this toggle switch in the ganged position.
2. Reinstall the access panel.

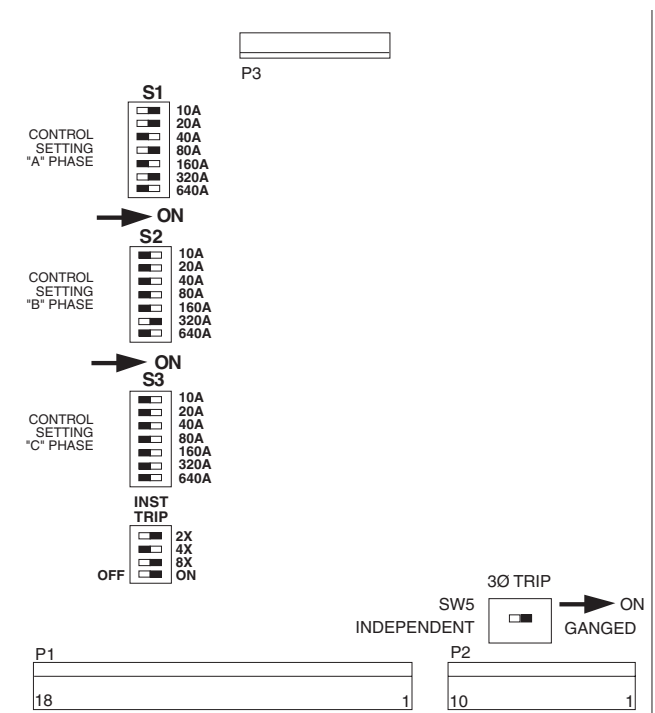

Figure 3.
Tri-Phase VFI circuit board modification.

To convert from three-phase trip back to single-phase trip, follow the above procedure except place the three-phase toggle switch in the “independent” position.

Manual Reset

Manual reset of the tripped interrupters is accomplished by first using the shotgun stick to pull each single-phase VFI operating handle individually, from either the tripped or closed position to its OPEN position, in order to properly reset the trip latches of the VFI mechanism.

NOTE: The ganging tool is not used to perform this step.

Operation

CAUTION: Verify that each phase is closed by testing for presence of line voltage on each phase. The CLOSED position of the ganged yellow operating handle does not indicate that the phases are closed. T257.0

The ganging tool can be used to perform both three-phase opening and three-phase closing operations. However, each operating handle must be individually reset before attempting to close.

The ganging tool is installed on a shotgun stick and engaged with the three operating handles, so that all three handles can be pushed or pulled simultaneously. Refer to Figure 4.

To Gang Open Three Single-Phase VFIs

1. Install the ganging tool onto the shotgun stick: grasp the mounting hole in the tool and lock in place.
2. Engage fingers of ganging tool in the three VFI handles.
3. Firmly pull VFI handles to their OPEN position.
4. Disengage ganging tool from the VFI handles.

To Gang Close Three Single-Phase VFIs

1. Using a shotgun stick, manually reset each VFI handle individually by firmly pulling each to the OPEN position.

Note: Do not use the ganging tool to perform this step.

2. Install the ganging tool onto the shotgun stick: grasp the mounting hole in the tool and lock in place.
3. Engage fingers of ganging tool in the three VFI handles.
4. Firmly push VFI handles to their CLOSED position.
5. Disengage ganging tool from the VFI handles.

If one or more VFI handles immediately drop back to the tripped position, the handles were not properly reset. Repeat Steps 1 through 5. All three handles dropping back to tripped position indicates an overcurrent condition likely exists.

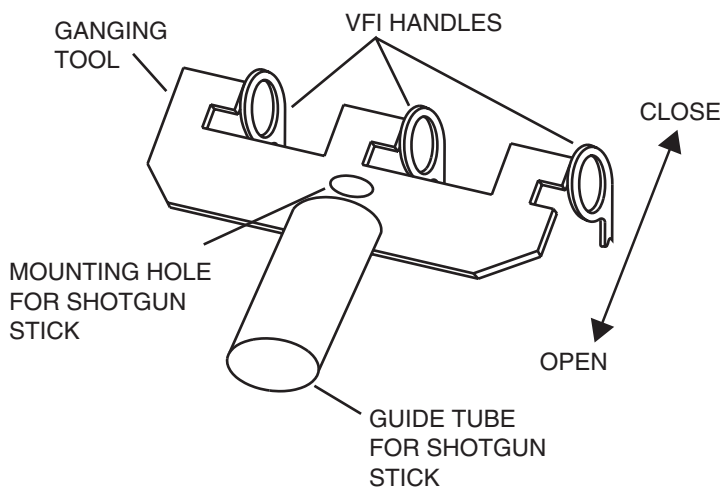

Figure 4.
Ganging tool engages VFI operating handles.

