

# Surge Arresters

## 15 and 25 kV Class VariGAP® and Standard Parking Stand Arrester Installation Instructions

S235-58-1

### Contents

General .....	1
Application .....	1
Safety Information .....	2
Installation Instructions .....	3

### GENERAL

The Cooper Power Systems MOV design and VariGAP® MOV gapped design parking stand arresters provide overvoltage protection to underground systems. They are designed to be installed in the parking stand bracket on the frontplate of a transformer or other apparatus.

**CAUTION:** The Cooper Power Systems Parking Stand Surge Arrester is designed to be operated in accordance with normal safe operating procedures. These instructions are not intended to supersede or replace existing safety and operating procedures. The Parking Stand Arrester should be installed and serviced only by personnel familiar with good safety practices and the handling of high-voltage electrical equipment. It may be removed from an energized system according to approved utility practices for removal of loadbreak terminators.

### APPLICATION

The parking stand arrester should be installed only on systems where the power frequency voltage at the arrester does not exceed maximum continuous operating voltage (MCOV) values published on page 3, Table 2.

The voltage rating and maximum continuous operating voltage are identified on a label on the arrester. If this information does not match the shipping order, please contact your Cooper Power Systems representative before installation.

**CAUTION:** Do not install an arrester if the voltage and MCOV data listed on the arrester label are not exactly the same as that listed on the carton label. Do not install arrester if system line-to-ground voltage exceeds the MCOV rating on the arrester.

**TABLE 1**  
Electrical Apparatus - Specifier's Catalog Section Number Reference

Arrester Design	Catalog Section Number
VariGAP MOV (Gapped)	235-58
Standard MOV	235-68

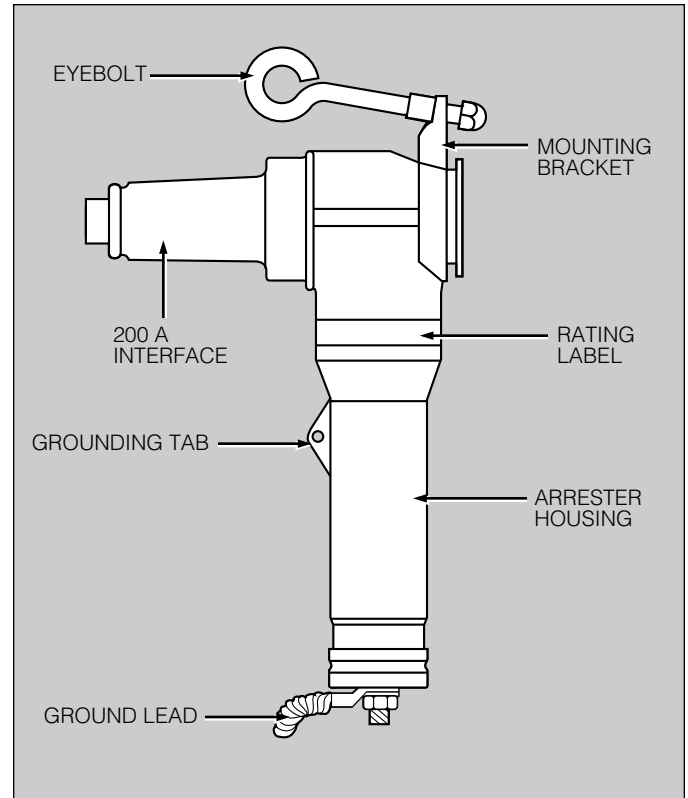

**Figure 1.**  
Line illustration of 25 kV Parking Stand Arrester.

**NOTE:** Because the parking stand arrester has a completely grounded case, it may be installed anywhere within the apparatus primary compartment. Determine the space requirements of the arrester and ground lead before installation, operation or removal of other devices.

*These instructions do not claim to cover all details or variations in the equipment, procedure, or process described, nor to provide directions for meeting every contingency during installation, operation, or maintenance. When additional information is desired to satisfy a problem not covered sufficiently for the user's purpose, please contact your Cooper Power Systems sales engineer.*



## SAFETY FOR LIFE



Cooper Power Systems products meet or exceed all applicable industry standards relating to product safety. We actively promote safe practices in the use and maintenance of our products through our service literature, instructional training programs, and the continuous efforts of all Cooper Power Systems employees involved in product design, manufacture, marketing and service.

We strongly urge that you always follow all locally approved safety procedures and safety instructions when working around high-voltage lines and equipment and support our “Safety For Life” mission.

## SAFETY INFORMATION

The instructions in this manual are not intended as a substitute for proper training or adequate experience in the safe operation of the equipment described. Only competent technicians, who are familiar with this equipment should install, operate and service it. A competent technician has these qualifications:

- *Is thoroughly familiar with these instructions.*
- *Is trained in industry-accepted high- and low-voltage safe operating practices and procedures.*
- *Is trained and authorized to energize, de-energize, clear, and ground power distribution equipment.*
- *Is trained in the care and use of protective equipment such as flash clothing, safety glasses, face shield, hard hat, rubber gloves, hotstick, etc.*

Following is important safety information. For safe installation and operation of this equipment, be sure to read and understand all cautions and warnings.

### Hazard Statement Definitions

This manual may contain four types of hazard statements:

 **DANGER:** Indicates an imminently hazardous situation which, if not avoided, will result in death or serious injury.

 **WARNING:** Indicates a potentially hazardous situation which, if not avoided, could result in death or serious injury.

 **CAUTION:** Indicates a potentially hazardous situation which, if not avoided, may result in minor or moderate injury.

**CAUTION:** Indicates a potentially hazardous situation which, if not avoided, may result in equipment damage only.

### Safety Instructions

Following are general caution and warning statements that apply to this equipment. Additional statements, related to specific tasks and procedures, are located throughout the manual.

 **DANGER:** Hazardous voltage. Contact with high voltage will cause death or severe personal injury. Follow all locally approved safety procedures when working around high- and low-voltage lines and equipment.

 **WARNING:** Before installing, operating, maintaining, or testing this equipment, carefully read and understand the contents of this manual. Improper operation, handling or maintenance can result in death, severe personal injury, and equipment damage.

 **WARNING:** This equipment is not intended to protect human life. Follow all locally approved procedures and safety practices when installing or operating this equipment. Failure to comply may result in death, severe personal injury and equipment damage.

 **WARNING:** Power distribution equipment must be selected for the intended application. It must be installed and serviced by competent personnel who have been trained and understand proper safety procedures. These instructions are written for such personnel and are not a substitute for adequate training and experience in safety procedures. Failure to properly select, install or maintain this equipment can result in death, severe personal injury, and equipment damage.

## INSTALLATION INSTRUCTIONS

**NOTE:** Verify parking stand arrester has the proper interface and voltage rating for the application.

**NOTE:** When the parking stand arrester is installed on an energized system, it must be positioned so that its grounded end points downward or at an adjacent grounding plane.

**NOTE:** Excessive force on the ground lead may cause the metal cap to separate from the arrester housing. Never handle the arrester by the attached ground lead.

**NOTE:** The nut attaching the ground lead to the threaded stud on the metal cap is factory installed to the proper torque value. Do not remove or retighten. Over torquing of the ground lead nut may cause the metal cap to separate from the arrester housing.

- Attach ground lead of arrester (connected to base of arrester) to system ground with 4 to 8 ft-lbs torque.
- Attach drain wire to grounding tab.
- Lubricate bushing interface of arrester with lubricant supplied.
- Grasp eyebolt on parking stand arrester with hotstick and install on parking stand bracket. Position arrester so that its grounded end points downward or at an adjacent grounding plane. Turn eyebolt clockwise to ensure rigid mounting.
- Verify ground lead attachment.
- Grasp pulling eye of loadbreak elbow to be installed on parking stand arrester with hotstick. Remove the loadbreak elbow from the bushing.
- After positioning elbow probe into nosepiece of parking stand arrester bushing, slowly insert elbow into bushing until a slight bump is felt.
- Thrust elbow firmly onto the arrester.
- Cover any exposed bushings with insulated protective caps.



**CAUTION:** The operator should not be looking directly at the connector during the moment of circuit interruption or connection. Positive control of the connector and cable should be maintained at all times. The operator should have a means of isolating an energized conductor readily available and convenient. Companies that operate separable connectors may have other requirements.



**CAUTION:** When not in use, the parking stand arrester must be covered with an insulated protective cap to keep the interface clean.

**TABLE 2**  
Recommended M.O.V.E.™ Arrester Applications

Nominal Circuit Voltage (kV)	Maximum Voltage (kV)	Duty Cycle (MCOV Ratings) (kV)		
		4-Wire Wye; Multi-grounded Neutral	3-Wire Wye; Solidly Grounded Neutral 30 minute <sup>2</sup>	Delta and Ungrounded Wye <sup>1</sup>
2.4	2.54	—	—	3 (2.55)
4.16 Y/2.4	4.4 Y/2.54	3 (2.55)	6 (5.1)	—
4.16	4.4	—	—	6 (5.1)
4.8	5.08	—	—	6 (5.1)
6.9	7.26	—	—	9 (7.65)
8.32 Y/4.8	8.8 Y/5.08	6 (5.1)	9 (7.65)	—
12.0 Y/6.93	12.7 Y/7.33	9 (7.65)	12 (10.2)	—
12.47 Y/7.2	13.2 Y/7.62	9 (7.65)	15 (12.7)	—
13.2 Y/7.62	13.97 Y/8.07	10 (8.4)	15 (12.7)	—
13.8 Y/7.97	14.52 Y/8.38	10 (8.4)	15 (12.7)	—
13.8	14.52	—	—	18 (15.3)
20.78 Y/12.0	22.0 Y/12.7	15 (12.7)/18 (15.3) <sup>3</sup>	21 (17.0)	—
22.86 Y/13.2	24.2 Y/13.97	18 (15.3)/21 (17.0) <sup>3</sup>	24 (19.5)	—
24.94 Y/14.4	26.4 Y/15.24	18 (15.3)/21 (17.0) <sup>3</sup>	27 (22.0)	—
27.6 Y/15.93	29.255 Y/16.89	21 (17.0)/24 (19.5) <sup>3</sup>	—	—
34.5 Y/19.92	36.51 Y/21.1	27 (22.0) <sup>4</sup>	—	—

1. Use for high impedance grounded systems also.

2. Line-to-ground fault duration not to exceed 30 minutes. For longer durations, contact factory for proper rating.

3. Selection of Cooper M.O.V.E.™ Arrester with a higher rated MCOV rating may improve the probability of surge sharing on systems not protected with MOV arresters at the riser poles.

4. The 22.0 kV MCOV rating is available only in the 35 kV Class Large Interface (Interface No. 1).



© 2005 Cooper Power Systems or its affiliates.  
M.O.V.E.™ is a trademark of Cooper Power Systems or its affiliates.  
VariGAP® is a registered trademark of Cooper Power Systems or its affiliates.  
#5000050704 **Rev. 05**

1045 Hickory Street  
Pewaukee, WI 53072 USA  
[www.cooperpower.com](http://www.cooperpower.com)