

OEM Equipment

Electrical Apparatus
800-71

150 A Single-Phase Series Multiple (Dual Voltage) Switches

GENERAL

The Cooper Power Systems 150 A externally operated Single-Phase series multiple (dual voltage) switch is used to change connection of de-energized transformer windings between series and parallel to provide different common transformer voltage ratios. They also make it possible to stock one transformer with voltage conversion capability. Using stacked multi-layer switches and auxiliary back switches, voltages such as 2400 V x 7620 V or 7200 V x 19920 V can be provided. Tri-voltage switches are also available.

Externally operable switches eliminate many of the hazards associated with manual internal tap changing of distribution transformers because line crews need not be exposed to high-voltage conductors and hot transformer fluids. They also eliminate the need to dismount pole-type transformers for voltage adjustment and prevent exposure of the transformer tank interiors to contamination. The switches are designed for use in distribution transformers filled with transformer oil, Envirotemp FR3 fluid or an approved equivalent.

Series multiple (dual voltage) switches are available with cap/wrench, lever, "T", or hotstick-operable handles. The lever handle has an indexing screw to ensure complete, positive switch contact. The cap/wrench handle has an innovative "one-way-in/one-way-out" operating feature that ensures positive operation. The threaded cap protects the shaft seal. The spring-loaded pad lockable handle is hotstick-operable. It allows greater leverage and provides positive indication of switch position.



Figure 1.
150 A Externally Operated Series Multiple (Dual Voltage) Switch, with Cap Wrench.



Figure 2.
150 A Externally Operated Series Multiple (Dual Voltage) Switch, with Lever Handle.

TABLE 1
Voltage Ratings and Characteristics

| Description | kV |
|--|---------|
| Standard Voltage Class | 35 Max. |
| AC 60 Hz 1 Minute Withstand | 50 |
| BIL and Full Wave Crest (in both series and parallel positions) | 150 |

Voltage ratings and characteristics are in accordance with IEEE Std C57.12™ standard.

TABLE 2
Current Ratings and Characteristics

| Description | Amperes |
|-------------|--|
| Continuous | 150 A rms series position 300 A rms parallel position |

The switch shaft is made of a high strength glass-reinforced nylon, and is sealed against leakage by two high temperature resistant Viton® O-rings. The switch body and rotor are made of glass-reinforced polyester. The spring tempered, high conductivity copper pinch-type rotor contacts, provide dependable self-cleaning action.

Series multiple (dual voltage) switches are available with either bolt tab or crimp terminals. Switches with crimp terminals have additional inboard tapped holes for making separate ring tongue connections without changing switch contacts. All terminals have hex recesses to hold 7/16 inch hex bolt heads of standard 1/4 inch hardware for fast, easy connections.

INSTALLATION

No special tools are required. The switch body is installed through a keyed 1.33 inch (34 mm) hole in the tank wall and sealed by an inside gasket. An outer sealing nut is tightened to a torque of 80 to 120 in-lbs. Refer to Installation Instruction Sheet S800-72-1 for details.

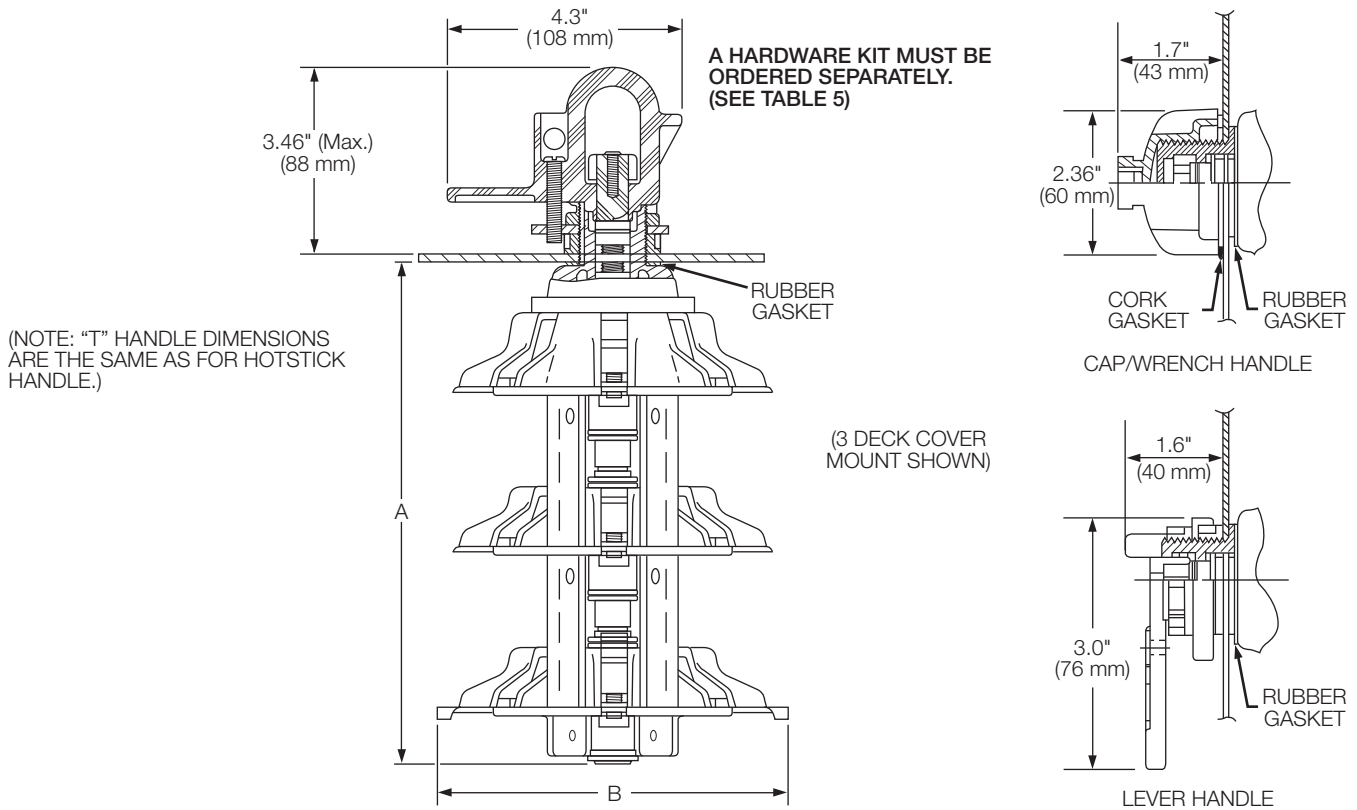

Figure 3.
Series Multiple Switch. (Padlockable Hotstick Handle Options Shown On Switch.)

Note: Dimensions given are for reference only.

TABLE 3
Multiple Switch Configurations

| Switch Type | Dimensions-in./(mm) | | | | |
|--|---------------------|-----------------|-----------------|------------------|----------|
| | A | B (w/Terminals) | | | |
| | | Bolt Tab | Bolt Tab w/Stud | #14-16 #10-12 #8 | #6 |
| 1-Phase Standard (1 Deck) | 3.31 | 5.52 | 5.52 | 6.63 | 6.88 |
| | (84 mm) | (140 mm) | (140 mm) | (168 mm) | (175 mm) |
| 1-Phase With Back Decks (2 Decks) | 5.713 | 5.52 | 5.52 | 6.63 | 6.88 |
| | (145 mm) | (140 mm) | (140 mm) | (168 mm) | (175 mm) |
| 1-Phase Cover Mount (3 Decks) ^① | 9.20 | 5.52 | 5.52 | 6.63 | 6.88 |
| | (232 mm) | (140 mm) | (140 mm) | (168 mm) | (175 mm) |

^①The upper two decks have no contacts – for spacing only.

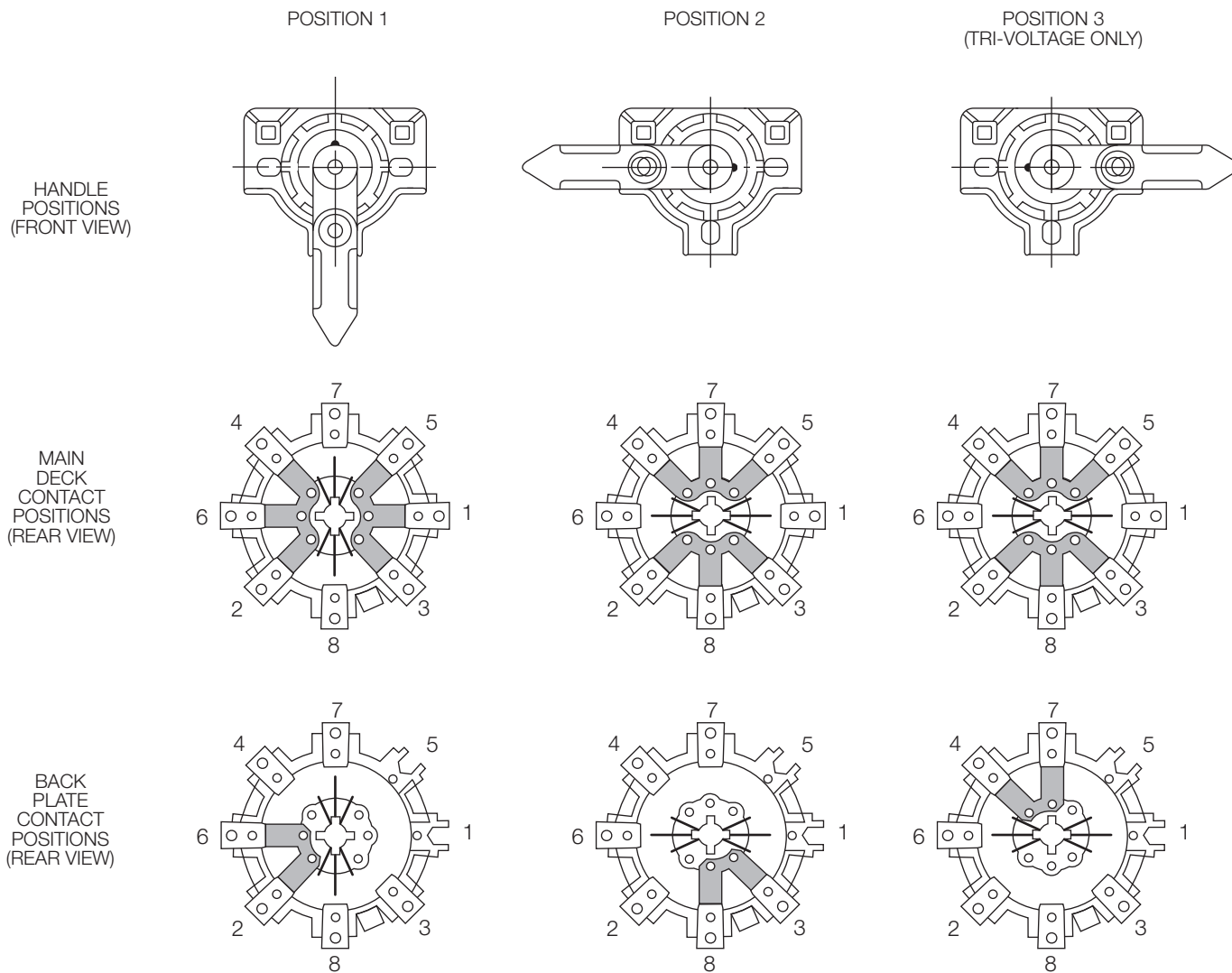

Figure 4. Switch Contact Positions. (Typical switch shown. For specifics refer to Table 5.)

ORDERING INFORMATION

To order a Cooper Power Systems 150 A externally operated series multiple switch, specify one switch and one hardware kit from the charts on pages 4-5.

TABLE 4
Abbreviations and Definitions

| | |
|---------|---|
| "DV" | Dual Voltage, 6 or 8 Terminals, 2-3 Finger Contacts. |
| "TV" | Tri-Voltage, 6 or 8 Terminals, 2-3 Finger Contacts. |
| "BP" | Backplate (Backswitch), 4 Terminals, 2 Finger Contacts. |
| "DBP" | Double Backplate, 8 Terminals, 2-2 Finger Contacts. |
| "2BP" | Two Backplates, 4 Terminals each, 2 Finger Contacts each. |
| "1BP" | One Backplate, at end of switch, 4 Terminals, 2 Finger Contacts. |
| "TD" | Terminal Deck, 2 Terminals (B.T.), w/o Rotor Assembly or Finger Contacts |
| "CM/DV" | Cover Mounted Switch. |
| "SP" | Special Switch with non-standard quantities and placements of terminals and contacts. |

TABLE 5
Cap Wrench or Lever Handle Operated Series Multiple Switches^⑤

| Catalog Number | | Switch Type ^⑥ | Description | | Contacts | No. of Terminals on Front Phase Deck | "N" Drawing No. |
|--|--|--|----------------------------------|----------------------------------|--|--------------------------------------|-----------------|
| Switch Number | Hardware Kit ^{①②} TV | DV DM/DV | Phase | Back Deck ^⑥ | Bolt Tab Bolt Tab w/Stud ^③ | | |
| | | | One | BP, DBP 1BP, SP | #14-16 #10-12 #8, #6 | | |
| 2237434C01M 2237434C02M 2237434C03M 2237434C04M 2237434C05M 2237434C16M | Cap Wrench 2237947A02 or Lever Handle 2237947A08 ^④ | DV DV DV DV DV DV | 1Ø 1Ø 1Ø 1Ø 1Ø 1Ø | — — — — — — | Bolt Tab #14 - 16 #10 - 12 #8 #6 Bolt Tab w/Stud ^③ | 6 6 6 6 6 6 | 720 |
| 2237434C51M 2237434C52M 2237434C53M 2237434C54M 2237434C55M 2237434C66M | Cap Wrench 2237947A02 or Lever Handle 2237947A08 ^④ | DV DV DV DV DV DV | 1Ø 1Ø 1Ø 1Ø 1Ø 1Ø | — — — — — — | Bolt Tab #14 - 16 #10 - 12 #8 #6 Bolt Tab w/Stud ^③ | 8 8 8 8 8 8 | 720 |
| 2237435C01M 2237435C02M 2237435C03M 2237435C04M 2237435C05M 2237435C06M | Cap Wrench 2237947A02 or Lever Handle 2237947A08 ^④ | DV DV DV DV DV DV | 1Ø 1Ø 1Ø 1Ø 1Ø 1Ø | BP BP BP BP BP BP | Bolt Tab #14 - 16 #10 - 12 #8 #6 Bolt Tab w/Stud ^③ | 6 6 6 6 6 6 | 721 |
| 2237435C51M 2237435C52M 2237435C53M 2237435C54M 2237435C55M 2237435C66M | Cap Wrench 2237947A02 or Lever Handle 2237947A08 ^④ | DV DV DV DV DV DV | 1Ø 1Ø 1Ø 1Ø 1Ø 1Ø | BP BP BP BP BP BP | Bolt Tab #14 - 16 #10 - 12 #8 #6 Bolt Tab w/Stud ^③ | 6 6 8 8 8 8 | 721 |
| 2237492C01M 2237492C02M 2237492C03M 2237492C04M 2237492C05M | Cap Wrench 2237947A02 or Lever Handle 2237947A08 ^④ | DV DV DV DV DV | 1Ø 1Ø 1Ø 1Ø 1Ø | DBP DBP DBP DBP DBP | Bolt Tab #14 - 16 #10 - 12 #8 #6 | 6 6 6 6 6 | 867 |
| 2237984C01M 2237984C02M 2237984C03M 2237984C04M 2237984C05M | Cap Wrench 2237947A02 or Lever Handle 2237947A08 ^④ | DV DV DV DV DV | 1Ø 1Ø 1Ø 1Ø 1Ø | SP SP SP SP SP | #14 - 16 #10 - 12 #8 #6 Bolt Tab | 8 8 8 8 8 | 915 |
| 2238066C06M 2238066C07M 2238066C08M 2238066C09M 2238066C10M | Cap Wrench 2237947A02 or Lever Handle 2237947A08 ^④ | DV DV DV DV DV | 1Ø 1Ø 1Ø 1Ø 1Ø | SP SP SP SP SP | Bolt Tab #14 - 16 #10 - 12 #8 #6 | 8 8 8 8 8 | 913 |
| 2237576C01M 2237576C02M 2237576C03M 2237576C04M 2237576C05M 2237576C06M | Cap Wrench 2237947A02 Lever Handle 2237947A08 ^④ or Brass Cap Wrench 2237947A41 | CM/DV CM/DV CM/DV CM/DV CM/DV CM/DV | 1Ø 1Ø 1Ø 1Ø 1Ø 1Ø | SP SP SP SP SP SP | Bolt Tab #14 - 16 #10 - 12 #8 #6 Bolt Tab w/Stud ^③ | 6 6 6 6 6 6 | 798 |
| 2237576C51M 2237576C52M 2237576C53M 2237576C54M 2237576C55M 2237576C56M | Cap Wrench 2237947A02 Lever Handle 2237947A08 ^④ or Brass Cap Wrench 2237947A41 | CM/DV CM/DV CM/DV CM/DV CM/DV CM/DV | 1Ø 1Ø 1Ø 1Ø 1Ø 1Ø | SP SP SP SP SP SP | Bolt Tab #14 - 16 #10 - 12 #8 #6 Bolt Tab w/Stud ^③ | 8 8 8 8 8 8 | 798 |
| 2237438C01M 2237438C02M 2237438C03M 2237438C04M 2237438C05M | Lever Handle 2237947A09 ^④ | TV TV TV TV TV | 1Ø 1Ø 1Ø 1Ø 1Ø | BP BP BP BP BP | Bolt Tab #14 - 16 #10 - 12 #8 #6 | 6 6 6 6 6 | 724 |
| 2237438C51M 2237438C52M 2237438C53M 2237438C54M 2237438C55M | Lever Handle 2237947A09 ^④ | TV TV TV TV TV | 1Ø 1Ø 1Ø 1Ø 1Ø | BP BP BP BP BP | Bolt Tab #14 - 16 #10 - 12 #8 #6 | 8 8 8 8 8 | 724 |
| 2238011C01M 2238011C02M 2238011C03M 2238011C04M 2238011C05M | Lever Handle 2237947A09 ^④ | TV TV TV TV TV | 1Ø 1Ø 1Ø 1Ø 1Ø | SP SP SP SP SP | Bolt Tab #14 - 16 #10 - 12 #8 #6 | 8 8 8 8 8 | 925 |

①Hardware Kits are not included with the switch, Hardware Kits must be ordered separately. ②Actuating devices are included in the Hardware Kits.

③Bolt Tab w/Stud (1/4"-20 threaded stud). ④Add "P" to end of the part number to make lever handle padlockable.

⑤For configuration not found, consult with your factory representative. ⑥For abbreviations and definitions see Table 4.

TABLE 6
Padlockable Hotstick Handle or "T" Handle Operated Series Multiple Switches^④

| Catalog Number | | Switch Type ^⑤ | Description | | Contacts | No. of Terminals on Front Phase Deck | "N" Drawing No. |
|--|---|---|----------------------------------|----------------------------------|--|--------------------------------------|-----------------|
| Switch Number | Hardware Kit ^{①②} | DV CDM/ DV TV | Phase | Back Deck ^⑤ | Bolt Tab Bolt Tab w/Stud ^③ | | |
| | | | One | BP, DBP 2BP, 1BP SP, TD | #14-16 #10-12 #8, #6 | | |
| 2237262C01M 2237262C02M 2237262C03M 2237262C04M 2237262C05M 2237262C16M | Hotstick Handle 2237947A07 or "T" Handle 2237947A74 | DV DV DV DV DV DV | 1Ø 1Ø 1Ø 1Ø 1Ø 1Ø | — — — — — — | Bolt Tab #14 - 16 #10 - 12 #8 #6 Bolt Tab w/Stud ^③ | 6 6 6 6 6 6 | 595 |
| 2237262C51M 2237262C52M 2237262C53M 2237262C54M 2237262C55M 2237262C66M | Hotstick Handle 2237947A07 or "T" Handle 2237947A74 | DV DV DV DV DV DV | 1Ø 1Ø 1Ø 1Ø 1Ø 1Ø | — — — — — — | Bolt Tab #14 - 16 #10 - 12 #8 #6 Bolt Tab w/Stud ^③ | 8 8 8 8 8 8 | 595 |
| 2237264C01M 2237264C02M 2237264C03M 2237264C04M 2237264C05M 2237264C16M | Hotstick Handle 2237947A07 or "T" Handle 2237947A74 | DV DV DV DV DV DV | 1Ø 1Ø 1Ø 1Ø 1Ø 1Ø | BP BP BP BP BP BP | Bolt Tab #14 - 16 #10 - 12 #8 #6 Bolt Tab w/Stud ^③ | 6 6 6 6 6 6 | 597 |
| 2237264C51M 2237264C52M 2237264C53M 2237264C54M 2237264C55M 2237264C66M | Hotstick Handle 2237947A07 or "T" Handle 2237947A74 | DV DV DV DV DV DV | 1Ø 1Ø 1Ø 1Ø 1Ø 1Ø | BP BP BP BP BP BP | Bolt Tab #14 - 16 #10 - 12 #8 #6 Bolt Tab w/Stud ^③ | 8 8 8 8 8 8 | 597 |
| 2237485C01M | | DV | 1Ø | BP | Bolt Tab | 8 | 819 |
| 2238066C01M 2238066C02M 2238066C03M 2238066C04M 2238066C05M | Hotstick Handle 2237947A07 | DV DV DV DV DV | 1Ø 1Ø 1Ø 1Ø 1Ø | SP SP SP SP SP | Bolt Tab #14 - 16 #10 - 12 #8 #6 | 8 8 8 8 8 | 913 |
| 2237486C10M | | DV | 1Ø | SP | Bolt Tab | 6 | 787 |
| 2237465C01M 2237465C02M 2237465C03M 2237465C04M 2237465C05M | Hotstick Handle 2237947A04 or "T" Handle 2237947A70 | CM/DV CM/DV CM/DV CM/DV CM/DV | 1Ø 1Ø 1Ø 1Ø 1Ø | — — — — — | Bolt Tab #14 - 16 #10 - 12 #8 #6 | 6 6 6 6 6 | 735 |
| 2237268C01M 2237268C02M 2237268C03M 2237268C04M 2237268C05M | Hotstick Handle 2237947A06 or "T" Handle 2237947A73 | TV TV TV TV TV | 1Ø 1Ø 1Ø 1Ø 1Ø | BP BP BP BP BP | Bolt Tab #14 - 16 #10 - 12 #8 #6 | 6 6 6 6 6 | 603 |
| 2237268C51M 2237268C52M 2237268C53M 2237268C54M 2237268C55M | Hotstick Handle 2237947A06 or "T" Handle 2237947A73 | TV TV TV TV TV | 1Ø 1Ø 1Ø 1Ø 1Ø | BP BP BP BP BP | Bolt Tab #14 - 16 #10 - 12 #8 #6 | 8 8 8 8 8 | 603 |
| 2237661C01M | Hotstick Handle 2237947A06 | TV | 1Ø | SP | Bolt Tab | 8 | 816 |
| 2237674C01M | "T" Handle 2237947A73 | TV | 1Ø | SP | Bolt Tab | 8 | 820 |

①Hardware Kits are not included with the switch, Hardware Kits must be ordered separately. ②Actuating devices are included in the Hardware Kits.

③Bolt Tab w/Stud (1/4-20 threaded stud). ④For configuration not found, consult with your factory representative. ⑤For abbreviations and definitions see Table 4.

This page intentionally left blank.

This page intentionally left blank.

© 2009 Cooper US, Inc.

All Cooper logos, Cooper Power Systems, Envirotemp and FR3 are valuable trademarks of Cooper US, Inc. in the U.S. and other countries. You are not permitted to use the Cooper Trademarks without the prior written consent of Cooper US, Inc.

IEEE Std C57.12™ standard is a trademark of the Institute of Electrical and Electronics Engineers, Inc., (IEEE). This publication/product is not endorsed or approved by the IEEE.

Viton® is a registered trademark of E.I. DuPont Demours & Company



2300 Badger Drive
Waukesha, WI 53188 USA
www.cooperpower.com
