

OEM Equipment

Electrical Apparatus
800-57

100 A Externally Operated One-, Two- and Three-Phase Tap Changer Switch

GENERAL

Cooper Power Systems 100 A externally operated one-, two- and three-phase under-oil tap changer switch family eliminates many of the hazards associated with manual internal tap changing of distribution transformers. Line crews need not be exposed to high voltage conductors and hot transformer fluids. External operation also eliminates the need to dismount and open pole type transformers for voltage adjustment, which exposes the transformer tank interior to contamination.

The tap changer switch is designed for use in distribution transformers filled with transformer oil (mineral oil), Envirotemp FR3 fluid or an approved equivalent.

The switch body, rotor and shaft are made of a high strength, glass-filled thermoplastic material. The operating shaft is sealed against leakage by two high temperature resistant Viton® O-Rings.

Handle Options

Handle options include a cap/wrench, 2.25" lever (metal or thermoplastic), and hotstick operable. The cap/wrench features a white arrow inside the handle for position indication, and has a one-way-in/one-way-out operating feature that ensures positive operation. The threaded cap protects the shaft seal from contamination. The lever handle has an indexing screw to ensure complete, positive switch contact. The lever handle can be ordered with an optional padlockable feature. The hotstick handle is available in flexible, multi-piece, or rigid, one-piece configurations, with padlockable option available. (See Tables 5 and 8 for a complete listing.)

Stationary Contacts

For ease of connection, the following optional stationary contacts are available: bolt tabs, or 14-16 AWG, 12-10 AWG, or 8 AWG crimp terminals.

INSTALLATION

No special tools are required. The switch body is installed through a keyed 1.33 inch (34 mm) hole in the tank wall and sealed by an inside gasket. An outer sealing



Figure 1.
One-Phase Tap Changer with Cap/Wrench..

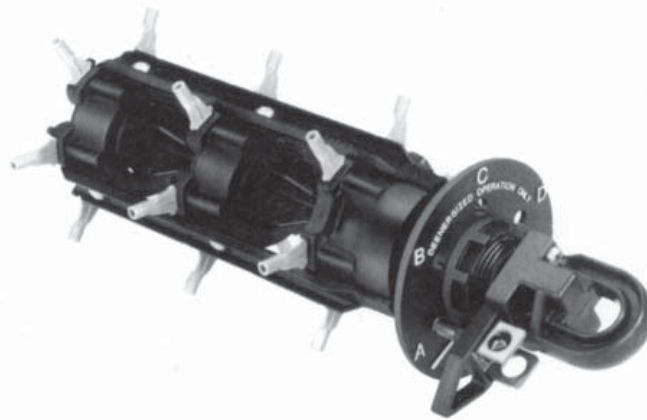

Figure 2.
Three-Phase Tap Changer with Padlockable Flexible Hookstick Pointer Handle and Index Plate..

nut is tightened to a torque of 80 to 120 in.-lb. Refer to Installation Instruction Sheet S800-57-1 (5000050574) for details.

TABLE 1
Voltage Ratings and Characteristics

Description	kV
Standard Voltage Class	35 Max.
AC 60 Hz 1 Minute Withstand	50
BIL and Full Wave Crest	150

Voltage ratings and characteristics are in accordance with IEEE C57.12™ standard (Phase-to-Phase or Phase-to-Ground).

TABLE 2
Current Ratings and Characteristics

Description	Amperes
Continuous	100 A rms

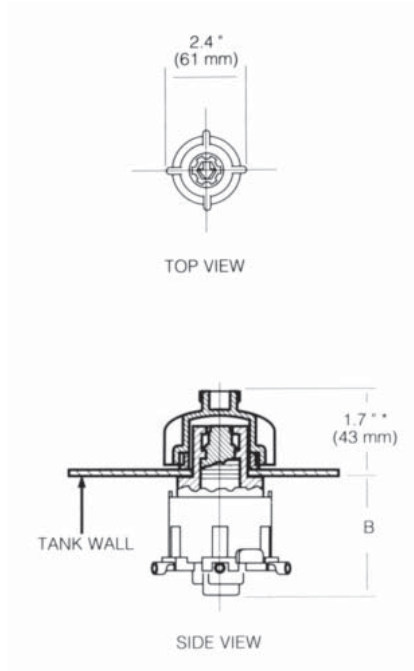

Figure 3.
One-Phase Cap/Wrench Operable Switch.

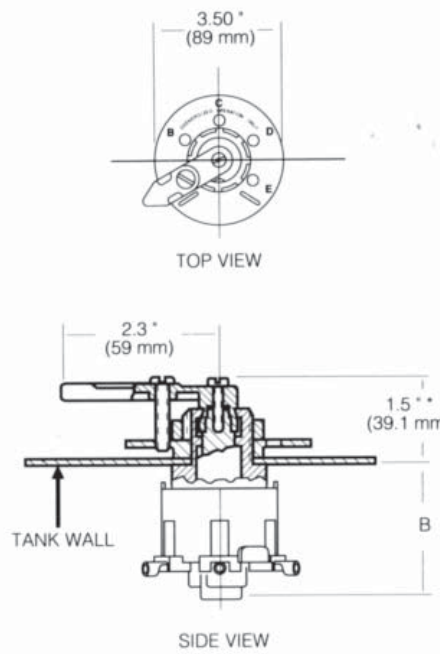

Figure 4.
One-Phase Lever Handle Switch.

TABLE 3
Switch Dimensions in./(mm)

Contact Type	A**	B
Bolt Tabs for 1/4" Bolts Bent 90°	2.91 (74)	2.81 (71)
16-14 AWG Terminals Short Shank	3.48 (88.4)	2.59 (66)
12-10 AWG Terminals Short Shank	3.48 (88.4)	2.59 (66)
8 AWG Terminals Short Shank	3.57 (90.7)	2.59 (66)
Bolt Tab Straight	4.47 (113)	2.59 (66)
16-14 AWG Terminals Long Shank	4.20 (107)	2.59 (66)
12-10 AWG Terminals Long Shank	4.20 (107)	2.59 (66)
8 AWG Terminals Long Shank	4.20 (107)	2.59 (66)
Bolt Tab Bent 45° 1/4-20 Threaded Stud	4.39 (113)	2.59 (66)
Bolt Tab Bent 90° 1/4-20 Stud	4.07 (103)	2.81 (74)
6 AWG Terminals Straight	5.74 (146)	2.59 (66)
6 AWG Terminals 45°	4.90 (125)	2.84 (73)

**A Dimension reflect use of standard length terminals on one-phase switches.

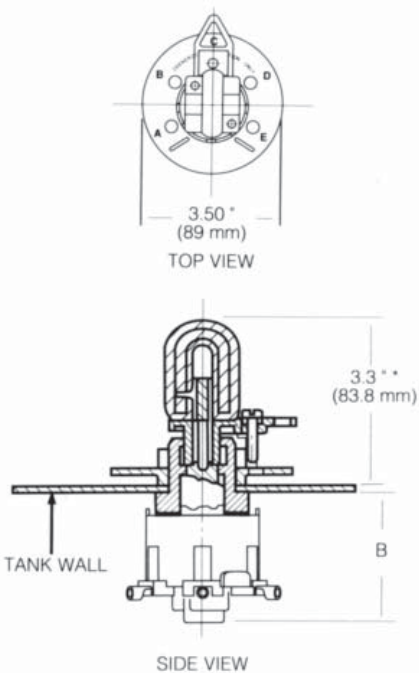

Figure 5.
One-Phase Flexible Hookstick Handle Switch.

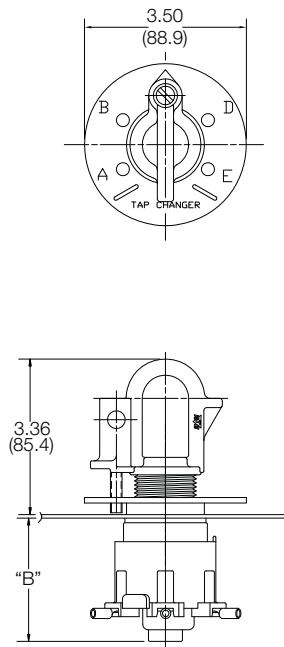

Figure 6.
One-Phase Rigid 1-Piece Hotstick Handle Switch.

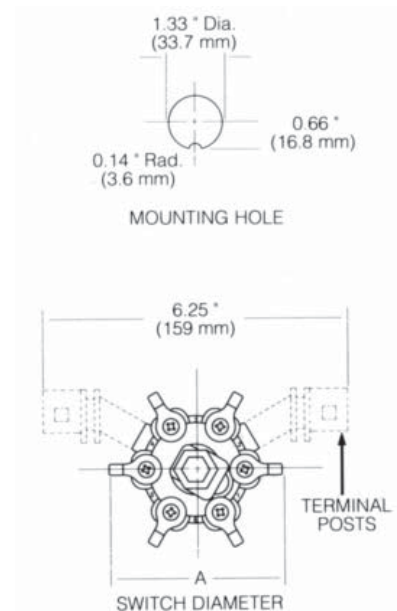

Figure 7.
One-Phase Mounting Hole and Switch with and without Terminal Posts.

NOTE: Dimensions given are for reference only.

* Dimensions will decrease as tank wall thickness increases. Maximum dimensions given with 14 gauge tank wall.

ORDERING INFORMATION**One-Phase Switch**

To order a Cooper Power Systems one-phase 100 A tap changer switch, specify catalog numbers for one switch and one handle kit.

**TABLE 4
One-Phase Switch**

Contact Type	Catalog Number
Tap Changer without Terminal Posts	
Bolt Tab - Bent 90° Accepts 1/4 inch Hardware	2237500C01
16-14 AWG Terminals	2237500C02
12-10 AWG Terminals	2237500C03
8 AWG Terminals	2237500C04
6 AWG Terminals Straight	2237500C134
6 AWG Terminals 45°	2237500C135
16-14 AWG Terminals Long Shank	2237500C12
12-10 AWG Terminals Long Shank	2237500C13
8 AWG Terminals Long Shank	2237500C14
Tap Changer with Terminal Posts	
Bolt Tab - Bent 90° Accepts 1/4 inch Hardware	2237500C06
16-14 AWG Terminals	2237500C07
12-10 AWG Terminals	2237500C08
8 AWG Terminals	2237500C09
6 AWG Terminals Straight	2237500C136
6 AWG Terminals 45°	2237500C137
16-14 AWG Terminals Long Shank	2237500C17
12-10 AWG Terminals Long Shank	2237500C18
8 AWG Terminals Long Shank	2237500C19

NOTE: Special Switch and Hardware Kits available on request. Contact your Cooper Power Systems representative for more information.

**TABLE 5
One-Phase Handle Kits**

Contact Type	Catalog Number
Handle Kits	
Cap/Wrench Combination Handle	2237947A14
Lever Handle, 2.25 inch, Metal Position A-E	2237947A39
Cap Wrench with Index Plate Position A-E	2237947A46
Padlockable Lever Handle, 2.25 inch, Metal Position A-E	2237947A44
Flexible Hookstick Handle, 2.25 inch Position A-E	2237947A127
Padlockable Flexible Hookstick Handle, 2.25 inch Position A-E	2237947A195
2.25 inch Thermoplastic Lever Handle	
100 A Tap Changer Position A - E	2237947A161
100 A Tap Changer Position 1 - 5	2237947A162
100 A Tap Changer Position 5 - 1	2237947A163
2.25 inch Thermoplastic Lever Handle with Padlock Clip	
100 A Tap Changer Position A - E	2237947A229
100 A Tap Changer Position 1 - 5	2237947A230
100 A Tap Changer Position 5 - 1	2237947A231
One-Piece Rigid Padlockable Hotstick Handle	
100 A Tap Changer Position A - E	2237947A301
100 A Tap Changer Position 1 - 5	2237947A302
100 A Tap Changer Position 5 - 1	2237947A303

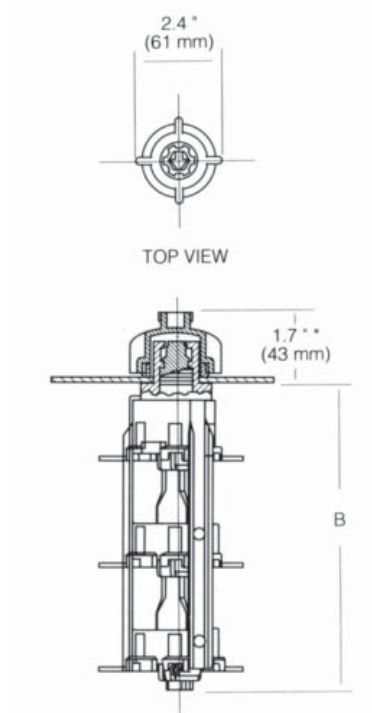

Figure 8.
Two and Three-Phase Cap/Wrench Operable Switch.

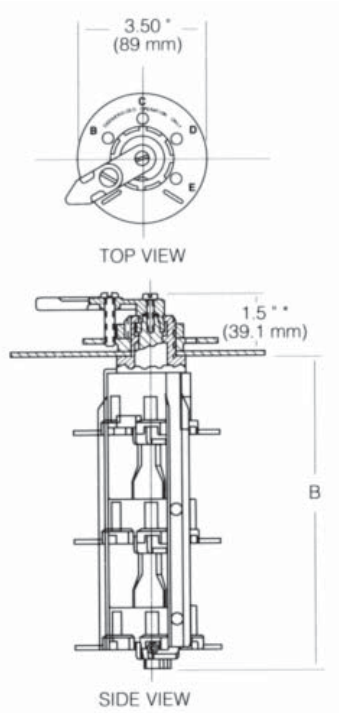

Figure 10.
Two and Three-Phase Lever Handle Switch.

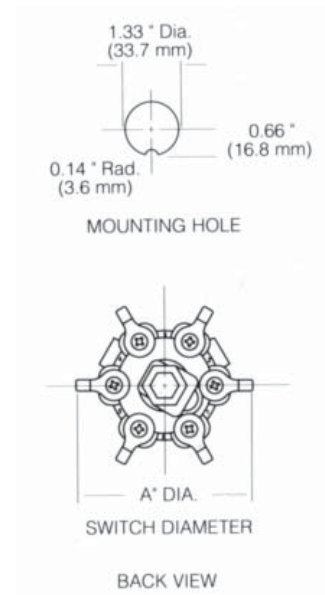

Figure 12.
Two and Three-Phase Mounting Hole and Switch Diameter.

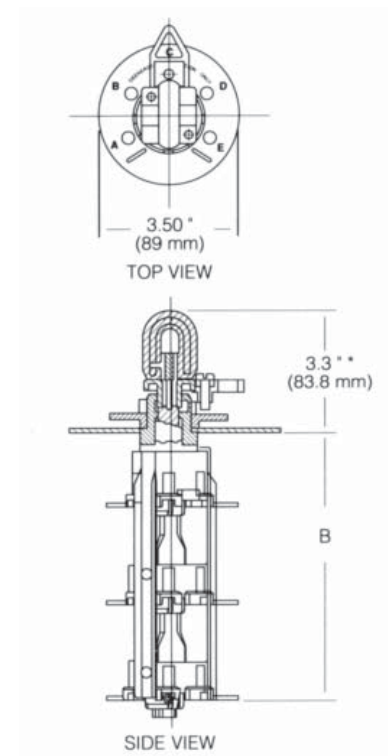

Figure 9.
Two and Three-Phase Flexible Hookstick Handle Switch.

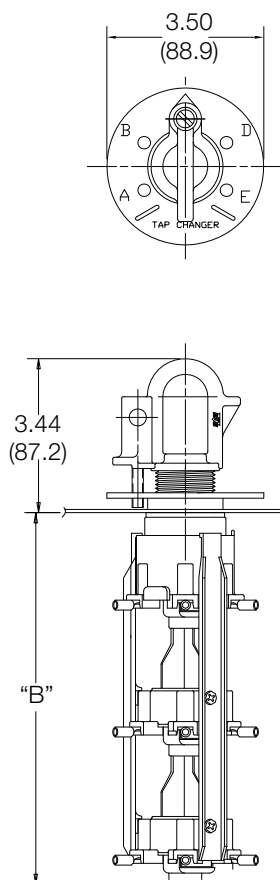

Figure 11.
One-Piece Rigid Hotstick Handle.

NOTE: Dimensions given are for reference only.

* Dimensions will decrease as tank wall thickness increases. Maximum dimensions given with 14 gauge tank wall.

TABLE 6
Switch Dimensions in./(mm)

Contact Type	A*	B (20)	B (30)
Bolt Tabs 90°	2.91 (74)	5.35 (135.9)	8.20 (208.3)
Bolt Tabs Straight	4.47 (113.4)	5.35 (135.9)	8.20 (208.3)
16-14 AWG Terminals Short Shank	4.20 (106.6)	5.35 (135.9)	8.20 (208.3)
12-10 AWG Terminals Short Shank	4.20 (106.6)	5.35 (135.9)	8.20 (208.3)
8 AWG Terminals Short Shank	4.20 (106.6)	5.35 (135.9)	8.20 (208.3)
Bolt Tab Bent 45° 1/4-20 Threaded Stud	4.38 (113)	5.43 (139)	8.36 (212)
Bolt Tab Bent 90° 1/4-20 Threaded Stud	4.07 (103)	5.56 (141)	8.55 (217)
6 AWG Terminals Straight	5.74 (146)	5.35 (136)	8.20 (208)
6 AWG Terminals 45°	4.90 (125)	5.60 (142)	8.45 (215)

*A Dimension reflect use of long shank terminals on Two-Phase and Three-Phase switches.

ORDERING INFORMATION

Two-and Three-Phase Switch

To order a two-phase or three-phase 100 A tap changer switch, specify catalog numbers for one switch and one handle kit.

TABLE 7
Two- and Three-Phase Switches

Contact Type	Catalog Number
Two-Phase Switches	
Bolt Tab - Bent 90° Accepts 1/4 inch Hardware	2237500C20
Bolt Tab Straight	2237500C21
16-14 AWG Terminals Long Shank	2237500C22
12-10 AWG Terminals Long Shank	2237500C23
8 AWG Terminals Long Shank	2237500C24
Bolt Tab - Bent 45° Accepts 1/4 inch Hardware	2237500C25
Bolt Tab - Bent 45° with 1/4 inch Stud	2237500C26
6 AWG Terminals Straight	2237500C138
6 AWG Terminals 45°	2237500C139
Three-Phase Switches	
Bolt Tab - Bent 90° Accepts 1/4 inch Hardware	2237500C30
Bolt Tab Straight	2237500C31
16-14 AWG Terminals Long Shank	2237500C32
12-10 AWG Terminals Long Shank	2237500C33
8 AWG Terminals Long Shank	2237500C34
Bolt Tab Bent 45° Accepts 1/4 inch Hardware	2237500C35
Bolt Tab Bent 45° with 1/4 inch Stud	2237500C36
Bolt Tab Bent 90° with 1/4 inch Stud	2237500C39
Bolt Tab Bent 45° with 1/4 inch Stud (Decks 1 & 2), Bolt Tab Bent 90° with 1/4 inch Stud (Deck 3)	2237500C141
6 AWG Terminals Straight	2237500C144
6 AWG Terminals 45°	2237500C145

NOTE: Special Switch and Hardware Kits available on request. Contact your Cooper Power Systems representative for more information.

TABLE 8
Two- and Three-Phase Handle Kits

Contact Type	Catalog Number
Handle Kits	
Cap/Wrench Combination Handle	2237947A14
Lever Handle, 2.25 inch, Metal Position A-E	2237947A39
Cap Wrench with Index Plate Position A-E	2237947A46
Padlockable Lever Handle, 2.25 inch, Metal Position A-E	2237947A44
Flexible Hookstick Handle, 2.25 inch Position A-E	2237947A127
Padlockable Flexible Hookstick Handle, 2.25 inch Position A-E	2237947A195
2.25 inch Thermoplastic Lever Handle	
100 A Tap Changer Position A - E	2237947A161
100 A Tap Changer Position 1 - 5	2237947A162
100 A Tap Changer Position 5 - 1	2237947A163
2.25 inch Thermoplastic Lever Handle with Padlock Clip	
100 A Tap Changer Position A - E	2237947A229
100 A Tap Changer Position 1 - 5	2237947A230
100 A Tap Changer Position 5 - 1	2237947A231
One-Piece Rigid Padlockable Hotstick Handle	
100 A Tap Changer Position A - E	2237947A301
100 A Tap Changer Position 1 - 5	2237947A302
100 A Tap Changer Position 5 - 1	2237947A303

© 2007 Cooper Power Systems, Inc., or its affiliates.
Envirotemp and FR3 are valuable trademarks of Cooper Industries in the U.S. and other countries. You are not permitted to use the Cooper Trademarks without the prior written consent of Cooper Industries.
IEEE C57.12™ is a trademark of the Institute of Electrical and Electronics Engineers, Inc.
Viton® is a registered trademark of DuPont Performance Elastomers.

COOPER Power Systems

2300 Badger Drive
Waukesha, WI 53188 USA
www.cooperpower.com