

Deadbreak Apparatus Connectors

600 A 15/25 kV Class Bol-T™ Deadbreak Connector

GENERAL

The Cooper Power Systems 600 A, 15/25 kV Class Bol-T™ Deadbreak Connector is used to terminate high-voltage underground cable on deadfront apparatus such as transformers, switches and switchgear. It is fully shielded, submersible and meets the requirements of **IEEE Standard 386™** – “Separable Insulated Connector Systems”.

The capacitive test point on the insulating plug provides a means of testing the circuit without disturbing the bolted connection.

In addition to the capacitive test point feature on the insulating plug, Cooper Power Systems offers an optional capacitive test point similar to the test points on Cooper 200 A Elbows. This allows the use of the Type “TPR” Series Fault Indicators, and provides a hotstick operable means of determining circuit condition when used with high impedance voltage sensing devices designed for test points.

Bol-T Connectors are designed for use on solid dielectric cable (XLPE or EPR) with extruded semi-conductive shields and concentric neutral, with or without a jacket.

Installation on jacketed concentric neutral cable may require additional sealing material. Cold shrinkable adapters are available for tape shield, linear corrugated and drain wire cable adaptation for use with deadbreak connectors.

900 AMP RATING

The Bol-T is rated for 900 A continuous when used with a copperside compression connector, copper insulating plug, copper stud and copper bushing or junction. If a 900 A rating is desired, specify a “C” as the 9th digit when determining your part number. See Step 3, page 4.

INTERCHANGEABILITY

All Cooper Power Systems 600 A Deadbreak Connectors conform to the electrical, mechanical and dimensional requirements of **IEEE Standard 386™**. The connectors can be used on any comparably rated bushing interface that also meets the requirements of this standard. In addition, all cable



Figure 1. 600 A Deadbreak Connector without test point; also available with test point.

adapters, insulating plugs, compression connectors and other component parts are designed to be interchangeable with those currently available from all other manufacturers that also comply with **IEEE Standard 386™**.

INSTALLATION

A torque wrench and one-inch socket are used to tighten the insulating plug through the compression connector within the T-Body onto a de-energized 600 A bushing interface. Refer to Installation Instruction Sheet 600-10-2 for details.

PRODUCTION TESTS

Tests conducted in accordance with **IEEE Standard 386™**:

- AC 60 Hz 1 Minute Withstand – 40 kV
- Minimum Corona Voltage Level – 19 kV

Tests conducted in accordance with Cooper Power Systems requirements:

- Physical Inspection
- Periodic Dissection
- Periodic X-ray Analysis

TABLE 1 Voltage Ratings and Characteristics

Description	kV
Standard Voltage Class	25
Maximum Rating Phase-to-Ground	15.2
AC 60 Hz 1 Minute Withstand	40
DC 15 Minute Withstand	78
BIL and Full Wave Crest	125
Minimum Corona Voltage Level	19

Voltage ratings and characteristics are in accordance with **IEEE Standard 386™**.

TABLE 2 Current Ratings and Characteristics

Description	Amperes
Continuous	600 A rms
24 Hour Overload	1,000 A rms
Short Time	40,000 A rms symmetrical for 0.17 s 27,000 A rms symmetrical for 4.0 s

Current ratings and characteristics are in accordance with **IEEE Standard 386™**.

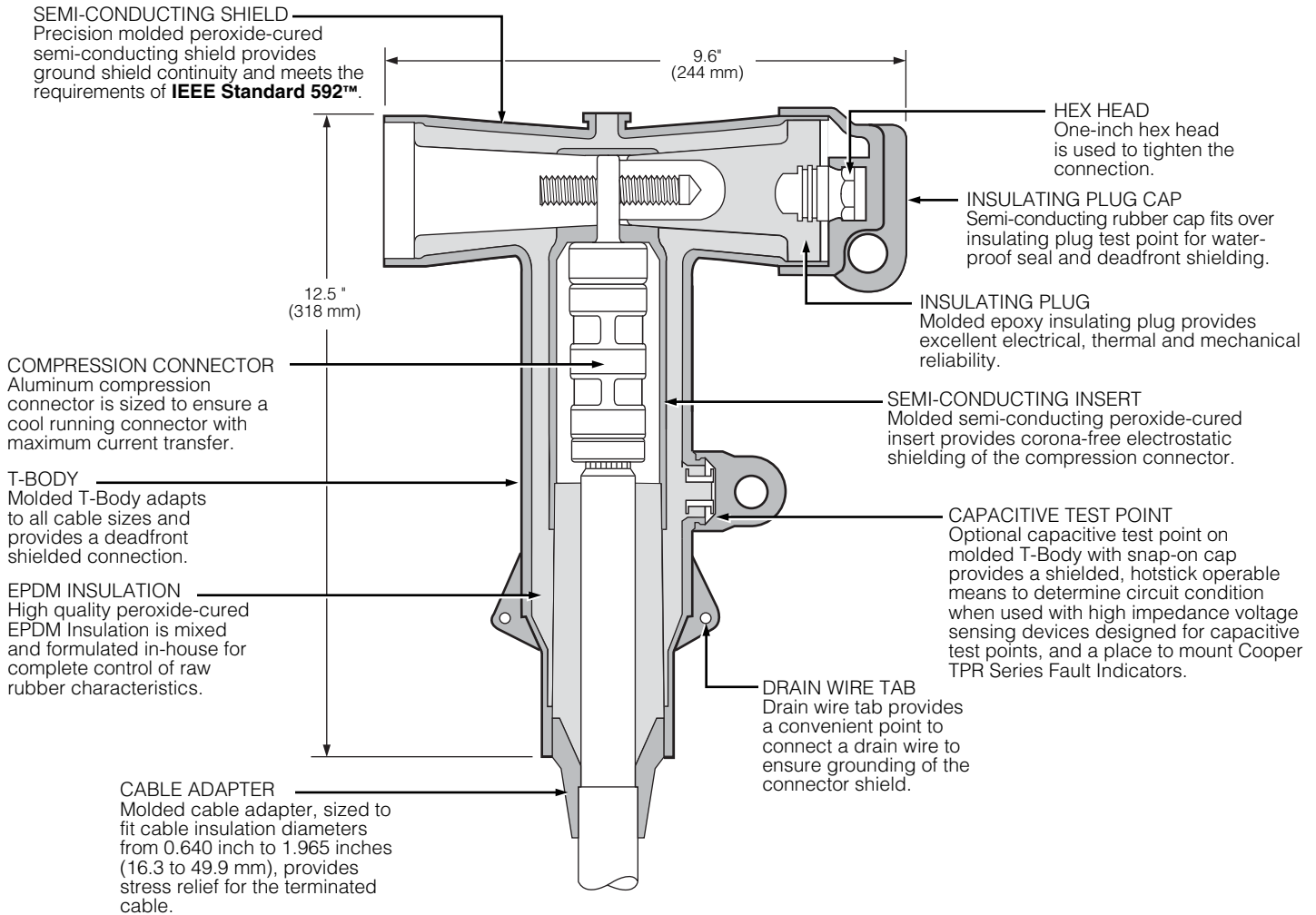

Figure 2.
Bol-T Cutaway illustrates design features.

Note: Dimensions given are for reference only.

OPTIONAL FEATURES

Coppertop Compression Connectors

Coppertop compression connectors (aluminum sleeve welded to a copper spade) provide a high conductivity material in a bolted connection and are compatible with aluminum or copper conductors.

All Copper Current Path

Full copper current carrying path and 900 A rating can be obtained by specifying a coppertop compression connector, copper stud and copper insulating plug.

ORDERING INFORMATION

Each Bol-T Connector kit contains:

- Molded Rubber T-Body
- Insulating Plug
- Insulating Plug Cap
- Compression Connector
- Cable Adapter
- Silicone Lubricant
- Installation Instruction Sheet

To order a 15/25 kV Class Bol-T Connector Kit, see following Steps 1-5 to build the catalog number.

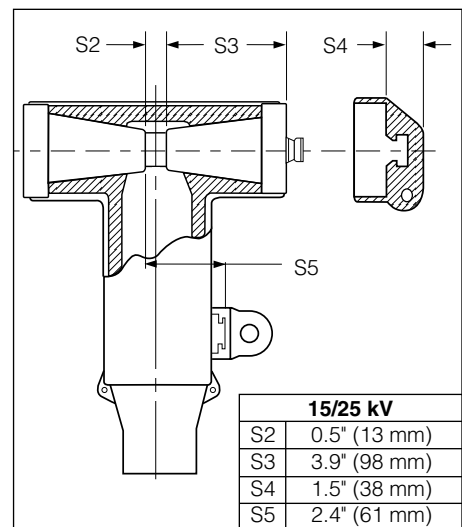

Figure 3.
Bol-T stacking dimensions.

Bol-T Connector Kit – Catalog Numbering System

Build the 11 digit catalog number for a Bol-T Kit by following the steps given below. The first 5 digits are “BT625”, so only digits 6 through 11 need to be selected.

1	2	3	4	5	6	7	8	9	10	11
B	T	6	2	5						

CATALOG NUMBER DIGITS:

1 & 2 = “BT”, Bol-T Connector System

3 = “6”, 600 A System

4 & 5 = “25”, 25 kV Class Bushing Interface

Step 1 – Select Digit 6 Cable Adapter Range Code

Determine the cable’s diameter over the electrical insulation as shown in Figure 4 (including tolerances).

Then identify a cable range from Table 3 that covers the minimum and maximum insulation diameters.

Select the correct CABLE RANGE CODE from Table 3.

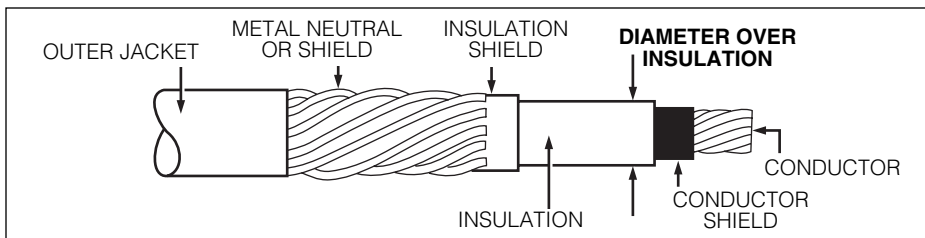

Figure 4.
Illustration showing typical construction of medium voltage underground cable.

TABLE 3
Cable Diameter Range

Cable Diameter Range					
Inches	mm	Code	Inches	mm	Code
0.640-0.760	16.3-19.3	A	1.220-1.420	31.0-36.1	G
0.720-0.845	18.3-21.5	B	1.360-1.560	34.5-39.6	H
0.785-0.970	19.9-24.6	C	1.480-1.700	37.6-43.2	J
0.910-1.065	23.1-27.1	D	1.640-1.840	41.7-46.7	K
0.980-1.140	24.9-29.0	E	1.780-1.965	45.2-49.9	L
1.080-1.280	27.4-32.5	F			

Step 2 – Select Digits 7 and 8 Conductor Code

Identify the conductor size and type in Table 4 and select the CONDUCTOR CODE from the far right column.

TABLE 4
Conductor Size and Type

Concentric or Compressed		Compact or Solid		CONDUCTOR CODE
AWG or kcmil	mm ²	AWG or kcmil	mm ²	
No Connector				00
2	–	1	–	11
1	–	1/0	–	12
1/0	50	2/0	70	13
2/0	70	3/0	–	14
3/0	–	4/0	95	15
4/0	95	250	120	16
250	120	300	–	17
300	–	350	–	18
350	–	400	185	19
400	185	450	–	20
450	–	500 ^a	240	21
500	240	600	300	22
600	300	700	–	23
650 ^b	–	750 ^c	–	24
750 ^d	–	900	–	25
900	–	1000	500	26
1000	500	–	–	27

a. Also accepts 550 kcmil compact conductor.

b. Also accepts 700 kcmil compressed conductor.

c. Also accepts 800 kcmil compact conductor.

d. Also accepts 700 kcmil concentric conductor.

Step 3 – Select Digit 9

Determine whether Aluminum or Copper is required for the compression connector, stud, and deadbreak insulating plug.

“A” = Aluminum

“C” = Copper (Coppertop for the connector) **Required to achieve 900 A rating.**

Step 4 – Select Digit 10

Determine if a stud should be included in the kit.

“1” = Stud Included

“2” = Stud Not Included

Step 5 – Select Digit 11

Determine if the T-Body should have a test point.

T = Test Point on T-Body

If no test point is required, do not include an 11th digit.

EXAMPLE: Select a Bol-T Kit for 250 kcmil compressed cable with a nominal insulation diameter of $1.160" \pm 0.030"$. The kit should have aluminum current-carrying parts and should have a stud included. The T- Body should have a test point.

Step 1 – Select Digit 6

Nominal diameter over insulation is $1.160" \pm 0.030"$.

Minimum diameter = $1.160" - 0.030" = 1.130"$.

Maximum diameter = $1.160" + 0.030" = 1.190"$.

From Table 3, identify the cable range that covers $1.130" - 1.190"$ and select the “F” cable range code.

Step 2 – Select Digits 7 and 8

The conductor size is 250 kcmil compressed. From Table 4, under the column “Concentric or Compressed,” identify 250 kcmil and select the “17” conductor code.

Step 3 – Select Digit 9

The kit should have aluminum current-carrying parts. Select an “A” for digit 9.

Step 4 – Select Digit 10

The kit should include a stud, so select 1 for digit 10.

Step 5 – Select Digit 11

A test point is needed, so use a “T” for digit 11.

The complete catalog number is:

BT625F17A1T

ACCESSORIES

Cable adapters, compression connectors, and other accessories that can be used with Cooper Power Systems’ Bol-T Connectors are described in Section 600-46, “Deadbreak Accessories, Tools, and Replacement Parts.”

TABLE 5
Replacement Parts

Description	Catalog Number
T-Body without Test Point	DT625
T-Body with Test Point	DT625T
T-Body without Test Point With Aluminum Stud	DT625SA
T-Body without Test Point With Copper Stud	DT625SC
T-Body with Test Point With Aluminum Stud	DT625TSA
T-Body with Test Point With Copper Stud	DT625TSC
Insulating Plug Cap	DIPCAP
Aluminum Insulating Plug with Cap (No Stud)	DIP625A
Copper Insulating Plug with Cap (No Stud)	DIP625C
Aluminum Insulating Plug with Cap and Aluminum Stud	DIP625AS
Copper Insulating Plug with Cap and Copper Stud	DIP625CS
$\frac{5}{8}$ " – 11 UNC 2A Aluminum Threaded Stud	STUD-A
$\frac{5}{8}$ " – 11 UNC 2A Copper Threaded Stud	STUD-C

ISO 9001:2000-Certified Quality Management System



© 2002 Cooper Industries, Inc.
BoI-T™ is a trademark of Cooper Industries, Inc.
IEEE Standard 386™ and IEEE Standard 592™ are trademarks of the Institute of
Electrical and Electronics Engineers, Inc.

P.O. Box 1640
Waukesha, WI 53187
www.cooperpower.com